

Regular Board Meeting
April 27, 2026 - 3:00 p.m.

AGENDA

- 1. Opening Business**
 - 1.1. Opening Prayer & Condolences - Deacon McPhee and Trustees
 - 1.2. Attendance
 - 1.3. Approval of the Regular Board Meeting Agenda of April 27, 2026. Pages 1-2
 - 1.4. Declaration of Interest
 - 1.5. Approval of the Regular Board Meeting Minutes of March 23, 2026. Pages 3-9
 - 1.6. Business Arising from the Minutes of the Regular Board Meeting of March 23, 2026.

- 2. Presentations**

- 3. Delegations**

- 4. Consent Agenda**
 - 4.1. Board Highlights for April Pages 10-19
 - 4.2. Approved Special Education Advisory Committee (SEAC) Meeting Minutes of March 9, 2026. Pages 20-23
 - 4.3. Approved Equity, Diversity, Inclusion and Anti-racism (EDIAR) Meeting Minutes of November 11, 2026 Pages 24-25
 - 4.4. Approved Catholic Parent Involvement Committee (CPIC) Meeting Minutes of October 21, 2025 Pages 26-29
 - 4.5. Approved Catholic Parent Involvement Committee (CPIC) Meeting Minutes of January 21, 2026 Pages 30-32
 - 4.6. Facility Project Approvals (Various) Pages 33-44
 - 4.7. Annual Drinking Water Report Pages 45-61

- 5. Committee and Staff Reports**
 - 5.1. Policy**
 - 5.1.1. Board Policies for review:
 - a) Assessment, Evaluation and Reporting (P2.2.8.) Pages 62-67
 - 5.1.2. Board Policies recommended for approval/rescinding:
 - a) Modified Day (P2.2.4.) Pages 68-70

 - 5.2. Student Achievement and Catholicity**
 - 5.2.1. Catholic Education Week report Pages 71-72
 - 5.2.2. Student Attendance Report Pages 73-76
 - 5.2.3. STEM Update Pages 77-78
 - 5.2.4. AI Summit and Parent Night Pages 79-81
 - 5.2.5. Student Trustees' Report Pages 82-84

5.3. Corporate Services and Operations

5.3.1.	February 28, 2026 Financial Report	Pages 85-87
5.3.2.	2026-2027 Budget Community Consultation	Pages 88-90
5.3.3.	2026-2027 Budget Report Preliminary Enrolment Projections	Pages 91-93

6. Information and Correspondence

- 6.1.** Core Ed Funding Update
- 6.2.** Parents of Black Children Update

7. Notices of Motion

8. Notices of Motion Considered for Adoption

9. Trustee Inquiries

10. In-Camera Session of the Regular Board Meeting

11. Rise and Report on the In-Camera Session of the Regular Board Meeting and Approval of the Business of the In-Camera Session

207 (2) Closing of certain committee meetings. A meeting of a committee of a board, including a committee of the whole board, may be closed to the public when the subject-matter under consideration involves: a. The security of the property of the board; b. The disclosure of intimate, personal or financial information in respect of a member of the board or committee, an employee or prospective employee of the board or a pupil or her or her parent or guardian; c. The acquisition or disposal of a school site; d. Decisions in respect of negotiations with employees of the board; or e. Litigation affecting the board.

12. Future Meetings and Events

- April 28, 2026 - Catholic Education Team meeting 4pm
- April 30 - May 2, 2026 - OCSTA AGM & Conference
- May 4, 2026 - CEW Mass, St. Patrick's, Dublin 5pm
- May 11, 2026 - SEAC meeting
- May 25, 2026 - Regular Board Meeting
- June 11-12, 2026 - SLICE
- Monday, June 15, 2026 - Regular Board Meeting

13. Closing Prayer - Deacon Dan McPhee, Board Chaplain

14. Adjournment

Regular Board Meeting
Monday, March 23, 2026 - 3:00 p.m.

MINUTES

Present:

Trustees: Vice-chair Amy Cronin (presiding); Trustees Tina Doherty; Sue Muller, and Jim McDade

Board Chaplain: Deacon Daniel McPhee

Student Trustee: Dean DeLuca, St. Michael CSS, Stratford, Addison Thuss, St. Anne's CSS, Clinton

Senior Administration: Director of Education & Secretary Karen Tigani; Superintendents of Education Tara Boreham, Sean McDade; Superintendent of Business & Treasurer Mary-Ellen Ducharme and Incoming Superintendent of Business & Treasurer Sarah Devereaux

Absent: Chair Mary Helen Van Loon

1. Opening Business

1.1. Opening Prayer & Condolences - Deacon Dan McPhee, Board Chaplain

1.2. Attendance - Noted above at start of meeting

1.3. Approval of Regular Board Meeting Agenda

Moved by: Tina Doherty

Seconded by: Sue Muller

THAT the Huron-Perth Catholic District School Board approves the agenda of the Regular Board Meeting of March 23, 2026.

Carried

1.4. Declaration of Interest

1.5. Approval of Regular Board Meeting Minutes

Moved by: Jim McDade

Seconded by: Sue Muller

THAT the Huron-Perth Catholic District School Board approves the minutes of the Regular Board Meeting of February 23, 2026.

Carried

1.6. Business Arising from the Minutes

2. Presentations

2.1. Math Program presented by Coordinator C. Dale

Coordinator Dale presented a comprehensive vision and plan for mathematics in the Huron-Perth CDSB, strategically aligning math processing skills with the Ontario Catholic Graduate Expectations and foundational values. The presentation detailed the "why, what, and how" of the district's instructional approach, highlighting a standardized scope and sequence, daily number talk routines, and the use of common assessments to ensure system-wide accountability. By walking Trustees through the Math Achievement Action Plan and current provincial priorities, Coordinator Dale illustrated what a consistent, effective math block looks like across the district, ensuring that high-quality mathematics instruction remains rooted in the board's Catholic identity.

3. Delegations

4. Consent Agenda

- 4.1.** March Board Highlights
- 4.2.** Approved Special Education Advisory Committee (SEAC) Meeting Minutes of February 10, 2025
- 4.3.** 2025 Public Sector Salary Disclosure Report
- 4.4.** Nutritional Management System Report
- 4.5.** 2026 Trustee Determination

Moved by: Tina Doherty

Seconded by: Sue Muller

THAT the Huron-Perth Catholic District School Board receives all reports, committee minutes, and approves all motions under the consent agenda, which are:

THAT the Huron-Perth Catholic District School Board receives the Board Highlights for March for information as corrected

AND

THAT the Huron-Perth Catholic District School Board receives the approved Special Education Advisory Committee (SEAC) Meeting Minutes of February 9, 2026

AND

THAT the Huron-Perth Catholic District School Board receives the 2025 Public Sector Salary Disclosure Report

AND

THAT the Huron-Perth Catholic District School Board receives the Nutritional Management System Report

AND

THAT the Huron-Perth Catholic District School Board approves the 2026 Trustee Determination

AND

THAT the Huron-Perth Catholic District School Board approves that there are no areas in the Huron-Perth Catholic District School Board's jurisdiction designated as low population areas.

Carried

5. Committee and Staff Reports

5.1. Policy

5.1.1. Board Policies for Review:

- a) Modified Day (P2.2.4.)

Trustees discussed the legal and procedural framework of the policy, inquiring if it was mandated by a Policy/Program Memorandum (PPM). Superintendent Boreham clarified that while not dictated by a PPM, the policy is rooted in the Education Act and was vetted by legal counsel upon initiation. The procedure includes critical safeguards to address unconscious bias and parental hardship, utilizing a collaborative team approach involving families, administrators, and Special Education coordinators. This process ensures that any modified attendance includes clear checkpoints and Superintendent approval, with the ultimate goal of supporting the student's transition to full-day attendance.

Moved by: Jim McDade

Seconded by: Sue Muller

THAT the Huron-Perth Catholic District School Board receives the following policy for review: Modified Day (P2.2.4.)

Carried

5.1.2. Board Policies Recommended for Approval/Rescinding:

- a) Concussion Management (P2.1.19.)
- b) Educational Field Trips (P2.2.3.)
- c) Development and Review of Board Policies (P1.1.4.)

THAT the Huron-Perth Catholic District School Board approves Policy Concussion Management (P2.1.19.), Educational Field Trips (P2.2.3.) and Development and Review of Board Policies (P1.1.4.).

Regarding the Educational Field Trips (P2.2.3) policy, trustees discussed the significant shifts in the landscape of school outings, specifically the rising costs of trips and the limited availability of transportation. The Board discussed the difficult decisions for principals regarding the financial viability, safety, and equity of trips, particularly when facing parental pressure. While there was a suggestion to add "relevance" and "increased risk" as specific criteria for approval, it was decided that the current language includes this.

Regarding the Development and Review of Board Policies (P1.1.4), the Board addressed the Director of Education's legislated responsibility to ensure all policies align with the Education Act, PPMs, and Ministry directives. A specific amendment was requested for the third bullet of item number six to clarify the Director's oversight. Additionally, the Director will develop a plan and guiding principles for Administrative Procedures (APs) with the possibility of linking them directly to their corresponding policies. This transition could begin during the regular review process to make guidance more accessible to the public.

Moved by: Tina Doherty

Seconded by: Sue Muller

THAT the Huron-Perth Catholic District School Board removes Development and Review of Board Policies (P1.1.4.) and places it as a separate consideration.

Carried

Moved by: Jim McDade

Seconded by: Sue Muller

THAT the Huron-Perth Catholic District School Board approves Policy Concussion Management (P2.1.19.) and Educational Field Trips (P2.2.3.)

Carried

Moved by: Tina Doherty

Seconded by: Jim McDade

THAT the Huron-Perth Catholic District School Board makes the following amendment to the policy Development and Review of Board Policies (P1.1.4.); Item number 6, third bullet to read “The Policy is within the scope of the Board’s authority as granted by provincial and federal stature with oversight by the Director of Education”.

Carried

Moved by: Jim McDade

Seconded by: Sue Muller

THAT the Huron-Perth Catholic District School Board approve policy Development and Review of Board Policies (P1.1.4.) with the approved amendment to Item number 6, third bullet to read “The Policy is within the scope of the Board’s authority as granted by provincial and federal stature with oversight by the Director of Education”.

Carried

5.2. Student Achievement and Catholicity

5.2.1. Artificial Intelligence Update

Moved by: Tina Doherty

Seconded by: Sue Muller

THAT the Huron-Perth Catholic District School Board receives the Artificial Intelligence (AI) Update for information.

Carried

5.2.2. Math Achievement Action Plan Update

Moved by: Tina Doherty

Seconded by: Jim McDade

THAT the Huron-Perth Catholic District School Board receives the Math Achievement Action Plan (MAAP) Update for information.

Carried

5.2.3. Literacy Update

Director Tigani and Superintendent Boreham provided a high-level summary of the report, which currently includes system-wide figures. To allow for data comparison, trustees requested that aggregated data be provided via email for future reports.

Moved by: Tina Doherty

Seconded by: Sue Muller

THAT the Huron-Perth Catholic District School Board receives the Literacy Update for information.

Carried

5.2.4. Student Trustees’ Report

Moved by: Jim McDade

Seconded by: Sue Muller

THAT the Huron-Perth Catholic District School Board receives the Student Trustees’ report for information.

Carried

5.3. Corporate Services and Operations

5.3.1. 2026-2027 Budget Community Consultation

Superintendent Ducharme outlined the communication plan and the framework for upcoming community consultations. During the discussion, Trustees requested a follow-up report containing hard data for their review and emphasized the importance of engaging the parish community in the survey process to gain broader insight. For future consideration, trustees recommended including a question regarding Catholic ratepayer status.

Moved by: Sue Muller

Seconded by: Jim McDade

THAT the Huron-Perth Catholic District School Board receives the 2026-2027 Budget Community Consultation Report.

Carried

5.3.2. Chromebook Purchase

During the discussion, trustees inquired whether new Chromebook models would include physical privacy sliders to protect students. Superintendent McDade confirmed that the selected model does feature a built-in camera shutter. To further ensure student safety, staff will integrate training on responsible camera use and include specific privacy expectations within the student Chromebook use agreement.

Moved by: Tina Doherty

Seconded by: Sue Muller

THAT the Huron-Perth Catholic District School Board approves the purchase of 475 chromebooks from CDW Canada at a cost of \$274,327.56.00 (including HST).

Carried

5.3.3. St. Mary's Catholic School Listowel Classroom and Child Care Centre Addition Report

Moved by: Jim McDade

Seconded by: Tina Doherty

THAT the Huron-Perth Catholic District School Board receives the St. Mary's Catholic School Listowel Classroom and Child Care Centre Addition Report.

Carried

6. Information and Correspondence

6.1. New Student Trustee Election results

Superintendent McDade shared the names of the newly elected student trustees for the 2026-27 school year: Ronnel Charles for St. Michael CSS and Quinn Palen for St. Anne's CSS. The new student trustees will be invited to the regular June Board meeting.

6.2. Letter from the Minister of Education - dated March 20, 2026 re: Graduation Ceremonies and Staff use of Social Media expectations.

Trustees discussed safety and protection measures. Director Tigani indicated that our graduation celebrations will continue to be about celebrating student achievement in our Catholic schools. The Director and Superintendents will discern with staff additional safety measures if deemed necessary.

7. Notices of Motion

8. Notices of Motion Being Considered for Adoption

9. Trustee Inquiries

- 9.1. Trustees inquired about Board issued printers and the cloud memory storage.
- 9.2. Trustees inquired about vape detectors for the secondary schools. Staff will look into the cost of this technology.
- 9.3. Trustees shared about the COR youth retreat taking place April 10-12 at the St. Patrick's School and church in Dublin and inquired if the board staff could assist with promoting the event.

10. In-Camera Session of the Regular Board Meeting

Moved by: Sue Muller

Seconded by: Tina Doherty

THAT the Huron-Perth Catholic District School Board moves to an In-Camera Session of the Regular Board Meeting

Carried

11. Rise and Report on the In-Camera Session of the Regular Board Meeting and Approval of the Business of the In-Camera Session

Moved by: Jim McDade

Seconded by: Tina Doherty

THAT the Huron-Perth Catholic District School Board approves all motions in the In-Camera Session of the Regular Board Meeting.

Carried

The following motion was approved:

THAT the Huron-Perth Catholic District School Board approves the recommendation from the Catholic Education Team THAT Dr. Vince McDonald be inducted into The Order of St. André Bessette for 2025.

AND

the following retirements were announced:

- Tracey Roy, Educational Assistant, St. Michael CSS, Stratford, effective February 27, 2026
- Sue Salter, Teacher, St. Aloysius School, Stratford, effective June 30, 2026

12. Future Meetings and Events

- March 25, 2026 - Catholic Parent Involvement Committee meeting
- April 22, 2026 - Equity, Diversity, Inclusion and Anti-racism Committee meeting
- April 20, 2026 - Special Education Advisory Committee meeting
- April 27, 2026 - Regular Board Meeting
- April 30 - May 2, 2026 - OCSTA AGM & Conference

13. Closing Prayer - Deacon Dan McPhee

14. Adjournment

Moved by: Sue Muller

Seconded by: Tina Doherty
THAT the Huron-Perth Catholic District School Board adjourns the Regular Board Meeting of
March 23, 2026.
Carried

VICE-CHAIR

SECRETARY



REPORT TO THE HURON-PERTH CATHOLIC DISTRICT SCHOOL BOARD

Prepared by: Tara Boreham and Sean McDade, Superintendents of Education
Presented to: The Huron-Perth Catholic District School Board
Date: Monday, April 27, 2026
Submitted by: Karen Tigani, Director of Education and Secretary

BOARD HIGHLIGHTS FOR APRIL

Public Session

BACKGROUND

Many activities take place every month throughout the district to ensure that our students have rich, faith-filled, inclusive learning opportunities that support their learning and fulfill the goals of the Strategic Plan. The Board Highlights list many of the activities that take place in the month prior to the board meeting, with contributions from Superintendents of Education, Learning Coordinators, the Mental Health Lead, the OYAP Project Lead, and Managers responsible for the activities under their leadership.

DEVELOPMENTS

The spiritual theme anchoring our Strategic Plan is “On Fire With The Spirit: Awaken! Illuminate! Rejoice!” Inspired by the Holy Spirit and enlivened by the Pentecost story, we go forward full of faith, hope, love and joy. We are excited about the incredible learning and growth that propels our students and staff forward as we journey together throughout the school year. April marks a vibrant time in our school year, filled with renewed energy and commitment. We are delighted to highlight some of the activities and opportunities that took place this month across our district.

CATHOLIC EDUCATION

Easter Season - On Fire with the Spirit in our Schools

Through the Lenten season, many schools participated in a variety of activities to help prepare for Holy Week and the Easter Triduum, culminating in the celebration of Christ’s resurrection. These activities included fundraising for the Share Lent Campaign, support for Project Precious and Chalice, food drives for St. Vincent de Paul and other local food banks, and prayers for peace in our world. Across the district, prayer services and Masses were held to celebrate the Lord’s resurrection. Priests from our Deanery offered opportunities for students and staff to receive the Sacrament of Reconciliation in our schools.

Development and Peace Schools (D & P Schools)

Schools throughout the system participated in the Major Mustard challenge as part of the D & P Schools program this Lent. Many schools collected funds for the Share Lent project. The theme for this year’s Share Lent Campaign “On Track for Justice” focuses on the efforts of Development and Peace to support decision-makers to prioritize people and our planet over mere profit, and demand debt justice for communities crushed by unjust and unpayable debts.

Diocese of London Collaborative Meeting

Director Tigani and Superintendent McDade attended a meeting with representatives from the Bishop's Office and Catholic school boards within the Diocese of London on April 14th. The meeting was designed to share information and practices related to nurturing the Catholic faith of students, families and staff who attend and are employed in our Catholic schools.

Furthermore, there was discussion about processes related to registration and how we can promote and support the ministry in parishes related to Baptism and RCIA in particular. Boards shared their approaches to supporting new families and new staff and expressed a shared commitment to continuing to work together to strengthen the school-home-parish partnership.

LEADERSHIP

Artificial Intelligence: Professional Development Day

Our Elementary Professional Development day, titled "The Heart Work in a Digital Age," was strategically designed to move all elementary staff beyond basic AI literacy toward meaningful integration that is firmly grounded in our Catholic values and upholds the dignity of the human person. We used a blended "Hub & Spokes" conference model, which balances expert broadcasts delivered from a central studio with local, facilitated small-group discussions at five regional hubs. The schedule featured a carefully scaffolded learning journey, progressing from foundational AI knowledge and ethical work to practical application with the PREP prompting framework, deep task redesign using tools like NotebookLM, and a final "Sandbox" session for role-specific consolidation and school planning, ensuring staff have professional agency through tailored learning tracks.

Secondary PD Day - April 24, 2026

Secondary staff participated in their school-based Faith Day on Friday, April 24th. This day was planned by a committee at each school (which included administration, teachers, chaplains, and other staff), and included all staff in various activities including Mass, prayer, reflection, and a menu of other options from which staff could choose. This is a reflection of the Board's commitment to faith formation for all staff as expressed in the multi-year strategic plan.

Fiat Fellowship Update

The *Fiat Fellowship*, our "Called to Serve" leadership initiative, continues to form and inspire emerging Catholic leaders across our system. Rooted in faith and aligned with our strategic theme *On Fire with the Spirit: Awaken, Illuminate, Rejoice*, the Fellowship integrates spiritual formation, leadership development, and experiential learning. We recently launched our first session, where retired Catholic Superintendent Lorrie Temple shared her personal faith and leadership journey, challenging fellows to reflect on how God may be calling them to a vocation in Catholic leadership. Many fellows have now begun their leadership placements, with host sites including St. Anne's and St. Michael Catholic Secondary Schools, St. Mary's Catholic Elementary Schools (Goderich and Listowel), Precious Blood Catholic Elementary School (Exeter), and placements at the Catholic Education Centre. In addition, fellows are actively engaged in the Notre Dame *Foundations of Catholic Belief* course, facilitated by Joe Bezzina and Religion Coordinator Caroline Thuss, and have successfully completed two modules to date. Our aspiring leadership program is off to a great start!

Dreams Delayed: Webinar to Support Implementation

Director Tigani and Superintendent Boreham attended a series of 2 webinars this month, designed to support Directors of Education and Superintendents responsible for Equity, Diversity, Anti-Racism and Inclusion to learn more about the key actions found within the

Ontario Human Rights Commission report “Dreams Delayed”. The webinars were organized by the Council for Directors of Ontario (CODE) and facilitated by highly respected lawyer, Njeri Damali Sojourner-Campbell (Hicks Morley LLP), a leading advisor and resource to educational leaders in the area of supporting school boards with equity, diversity and human rights.

Parents of Black Children Collaborative Meeting

Director Tigani and Superintendent Boreham met the leadership team from Parents of Black Children earlier this month. The meeting was requested by Parents of Black Children (POBC), to discuss the Huron-Perth Catholic DSB’s progress toward the actions identified in Dreams Delayed. An invitation was issued from POBC to all school boards in Ontario to meet for this purpose. The conversation underscored the imperative need to continue our efforts toward implementing the identified actions for education duty-holders.

LLC Update

On April 28, 2026, our leaders will meet for our monthly LLC. The morning will consist of the continuation of our Notre Dame course facilitated by Joe Bezzina. In the afternoon, leaders will convene for a session on the critical role of Tier 1 instruction as the primary driver of student success in literacy. Literacy Coordinator MJ Drager, joined by Literacy Resource Teachers Karen Kramers and Teresa Oud, will deliver an important presentation designed to challenge school leaders to look critically at the efficiency and impact of their current literacy schedules. The team will lead a deep dive into the specific components of an effective Tier 1 literacy block, emphasizing the importance of explicit, systematic instruction and the strategic use of every instructional minute to ensure equitable outcomes for all learners. To support this work in a practical way, the team will provide principals with a UFLI Principal Check-in List, a concrete tool designed to sharpen their instructional leadership. This checklist enables administrators to effectively monitor and support phonics lessons in the primary grades by identifying the specific, high-impact teacher moves that lead to reading proficiency. The day will conclude with Superintendent updates.

Primary and Junior EQAO

The EQAO Learning Coordinator met with each elementary principal to support onboarding to the e-assessment system, Vretta. To ensure a smooth 2026 assessment period, principals were provided with streamlined technical and administrative support. This included completing readiness checklist to ensure stable digital testing, managing staff portal access for vice-principals and invigilators, and validating student records to confirm that all required accommodations were accurately documented. Schools were also supported in scheduling Language and Mathematics sessions to ensure a student-centred approach and so all assessments are completed by the June 9 provincial deadline.

Illuminating Pathways: Faith, Learning and Leadership

Catholic Directors of Education and Supervisory Officers met for the annual Ontario Catholic Supervisory Officer Association (OC SOA) conference which included professional learning, faith formation and honouring retirees and commissioning of new members. This year, retiring Superintendent Mary Ellen Ducharme was honoured for her years of service. Superintendent of Business Sarah Devereaux was commissioned by Most Reverend Bishop Gerard Paul Bergie (Diocese of St Catharines). Commissioning is a sacred celebration that takes place during Mass. New superintendents from all Ontario Catholic school boards commit to humble service following the example of Jesus and are blessed by the bishop. Rooted in the Gospel of John 13:14-17, they receive a special OC SOA white towel, representing their commitment to “washing the feet” of students, parents and staff in their vocation. The professional learning portion of the conference included “Understanding Mental Health”, “Inclusive Leadership” and

“Spiritual Resiliency”. Attendees received a copy of Father John O’Brien’s book “6 Daily Habits for Spiritual Resiliency” based on Ignatian daily practices.

STUDENT ACHIEVEMENT

Mathematics

Throughout April, the Math Team maintained a strong presence in schools, working alongside principals and educators to advance mathematics teaching and learning. Support focused on co-planning, in-class modelling, and strengthening school-level monitoring of instruction and student progress. At Sacred Heart in Wingham, our priority school, we welcomed three Student Achievement Officers from the Ministry of Education to examine our Math Achievement Action Plan in practice. System leaders highlighted progress on our core priorities, knowing the curriculum, knowing the math, and knowing the learner, supported by current data. Classroom visits in Grades 3 and 6 provided concrete evidence of these priorities in action and opportunities to hear directly from students about their mathematical thinking.

In the lead-up to EQAO, Math Facilitators supported Grade 3 and 6 students using released assessment items to reinforce curriculum expectations and build confidence with problem solving. Instruction emphasized direct modelling and teacher think-alouds to help students navigate multi-step tasks with greater independence. System-wide, all elementary schools now have access to the Tier 2 intervention resource Do the Math to address unfinished learning in number sense and operations. Ongoing support from the Math Team is helping ensure consistent and effective use of this resource through targeted small-group instruction.

Professional learning also remained a priority, with 25 educators, including teachers, principals, and system staff, attending the Ontario Association for Mathematics Education conference. Learning focused on equity, assessment, curriculum, technology, and pedagogy, with a shared commitment to bringing these practices back to schools.

Literacy

Throughout the month of April, the System Literacy Team successfully launched a targeted intervention initiative across four school sites: St. Boniface, St. Joseph’s Clinton, Holy Name of Mary, and Precious Blood. Working directly within Kindergarten and Grade 1 classrooms, Literacy Resource Teachers (LRT) focused on the strategic goal of prevention, aiming to address literacy gaps while they were still small rather than waiting for them to widen into more significant challenges. This work involved a comprehensive approach where the LRTs delivered high-impact phonics lessons to the whole class while simultaneously pulling small groups of students to close specific, individualized learning gaps. Furthermore, the literacy team maintained a focus on progress monitoring to track student growth, ensuring that instruction was adjusted the moment a student mastered a skill and was ready to move on to the next level of complexity.

Early Development Instrument

In April, the district prioritized the Early Development Instrument (EDI), a population-based measure that assesses children’s developmental health and well-being in five key domains. This tool stands as an indicator of how well children are developing compared to their peers and helps identify areas where additional community or school support may be needed. Early Years Coordinator MJ Drager facilitated a half day learning session for every Kindergarten teacher, emphasizing the long-term importance of this data in shaping future student success. Following this professional development, teachers were provided the afternoon to complete the detailed questionnaires for their respective students. Due to this collaborative effort, the Board has

achieved a 100% completion rate for the EDI, and the district will now await the formal report from the Offord Centre scheduled for release next year.

French as a Second Language

During the month of April, the French Immersion and Core French programs saw professional growth through regional collaboration and specialized training. Three Junior French Immersion teachers traveled to London for a two-day workshop focused on Structured Literacy within the junior grades, a session facilitated by the West Region's Common European Framework of Reference for Languages (CEFR) group. This learning opportunity provided educators with high-yield strategies, specialized resources, and collaborative discussions regarding effective assessment practices tailored to the junior immersion classroom. Additionally, Learning Coordinator MJ Drager attended a regional CEFR coordinators meeting on April 2 to consolidate the collective work of the West Region and begin strategic planning for the upcoming school year. To wrap up, the Board's DELF (Diplôme d'études en langue française) correctors gathered at the CEC on April 8 for a refresher session led by Principal Shona Gracey. This training, conducted in French, ensures our staff are fully prepared to administer the DELF examinations, which will take place at St. Anne's CSS on May 11, 12, and 13 for our Grade 12 French students. French teachers deeply value this immersive learning and collaboration.

Ontario Secondary School Literacy Test (OSSLT)

St. Anne's CSS and St. Michael CSS completed the OSSLT on April 9 and April 15, respectively. In the weeks leading up to the test, literacy leads, literacy teams, and classroom teachers worked together to prepare students through practice activities and daily instruction. Administrators oversaw these efforts to make sure every student felt supported and ready for their test day.

Indigenous Education

The highlights below outline recent key initiatives and collaborative efforts that demonstrate our commitment to Indigenous Education, community partnership, and student engagement across the board.

- **Community Engagement & Networking**

Lambton College Pow Wow: Members of the Indigenous Education team attended the Lambton College Pow Wow. This provided a vital opportunity to network with regional partners, support local initiatives, and strengthen relationships with community members and Elders in a culturally significant setting.

- **Experiential Learning & Stewardship**

Kettle and Stony Point First Nation Collaboration: In a joint effort with the OYAP (Ontario Youth Apprenticeship Program) committee, we have finalized the design and begun production of 50 planter boxes for the Elders of Kettle and Stony Point First Nations. An additional 50 boxes are allocated for production in the Fall. This project fosters intergenerational connection and practical skill-building while supporting food sustainability concerns for Indigenous Elders and Community members.

- **Arts, Culture & Storytelling**

McMichael Canadian Art Collection: Art students from St. Michael CSS and St. Anne's CSS traveled to Kleinburg to explore early Indigenous art. This excursion allowed students to engage deeply with historical and contemporary Indigenous perspectives through visual media.

- **Tribal Visions Performances**

Students at St. James (Seaforth), St. Michael CSS, and St. Anne's CSS participated in immersive sessions with Tribal Visions. The presentations featured traditional Indigenous

storytelling alongside live demonstrations of Jingle dress, Fancy Shawl, and Hoop dancing.

- **Cross-Board Partnerships**

Inaugural Cultural Demonstration Day: Planning is currently underway for the 1st Annual Huron Perth Indigenous School Cultural Demonstration Day. This initiative is a landmark collaboration with the Avon Maitland District School Board (AMDSB), aimed at bringing students together for a day of shared learning and cultural celebration.

SPECIAL EDUCATION

ASET Conference

On April 17, all Learning Coordinators attended the Association of Special Education Technology (ASET) Conference as a team. The conference focused on the use of assistive technology, artificial intelligence, and innovative practices to support diverse learners. The learning was grounded in current classroom practice, informed by research, and responsive to the evolving needs of students across K-12 and beyond.

Our collective participation reflected a strong commitment to building system capacity and ensuring we are equipped with the most current tools and strategies to effectively meet student needs. Attending together also supported shared learning and alignment in how these practices are implemented across our schools.

World Autism Awareness Day

April marked Autism Awareness Month, and the Huron-Perth Catholic District School Board was proud to recognize World Autism Awareness Day on April 2, 2026. Schools were invited to engage in a variety of activities and use provided resources to celebrate and honour the diversity of the Autism spectrum. This initiative supported ongoing efforts to foster understanding, acceptance, and inclusive learning environments for all students.

Community Connections Event

On April 22, we successfully hosted our Community Connections event in partnership with our coterminous board, Avon Maitland District School Board, at Seaforth Public School. This well-attended event brought together over 25 local agencies to support families of students with autism, medical complexities, and developmental differences. Families had the opportunity to explore services and resources relevant to all stages of their child's journey, from elementary through to secondary and transition planning for life after graduation. The event ran from 5:00-7:30 PM and included a light supper, and a supervised sensory space for students. This event highlighted the strength of our community partnerships and our shared commitment to supporting students and families through accessible, collaborative support.

MENTAL HEALTH AND WELL-BEING

Stratford Police Service Presentation with AMDSB

On Thursday, April 16, the Huron-Perth Catholic District School Board Mental Health Lead co-presented alongside the Avon Maitland District School Board Mental Health Lead to the Stratford Police Service Leadership Team as part of Mental Health Services in Education. This session supported continued cross-sector collaboration focused on student safety, mental health, and overall community well-being across Huron and Perth counties. The presentation highlighted key regional frameworks and protocols that guide coordinated, compassionate, and

effective responses to student mental health needs, including the Huron-Perth Mental Health Crisis & Suicide Response Protocol, the Huron-Perth Child & Youth Sexual Violence Support Guide, and the Huron-Perth Tragic Event Framework. These shared resources promote consistency and alignment in practice across school boards, police services, and community partners. By sharing organizational context, shared frameworks, and system-level practices, partners strengthen collective understanding and enhance coordinated responses that support student safety, well-being, and mental health. We hope this presentation serves as an example of how strong, collaborative partnerships help implement and amplify mental health work across Huron and Perth.

MH Literacy for Guidance Counsellors Session:

On Friday, April 17, secondary educators, Guidance Counsellors, and Chaplains gathered at the Catholic Education Centre for a full day of professional learning focused on strengthening school-based mental health literacy. This learning opportunity was part of a course introduced by School Mental Health Ontario (SMH-ON) in fall 2025, the Board is proud to partner with SMH-ON as a participant in the first pilot project exploring the effectiveness of a facilitated approach to an online, asynchronous course model.

Designed to build educator confidence in recognizing, responding to, and supporting student mental health needs, participants completed all three course modules and engaged in rich, collaborative learning throughout the day. In addition, the group had the opportunity to deepen their skills in Emotion Validation Coaching with Dr. Jennifer McTaggart, learning practical strategies to meet students where they are, support co-regulation, and respond effectively within the scope of their secondary roles. While the course is tailored to guidance professionals, the content and strategies are highly relevant for all staff who provide direct support to students. This shared professional learning experience strengthens our collective capacity to respond to student concerns with consistency, care, and evidence-informed practices. By deepening mental health literacy across key roles, we are better positioned to identify emerging needs early and ensure students receive timely, appropriate support.

Mental Health Team Professional Development - EARL-V3 Training:

The Mental Health Team recently completed EARL-V3 training, a Ministry-sponsored, structured clinical risk assessment framework that supports school-based mental health professionals in identifying risk factors early and responding with appropriate, evidence-informed interventions. EARL-V3 emphasizes that recognizing risk carries an ethical responsibility to act, guiding practitioners from assessment to meaningful, student-centred intervention. The tool supports the development of clear, targeted plans with students and families by linking each identified risk factor to suggested management strategies, while still relying on the practitioner's knowledge of local resources and school-based support. This training strengthens our team's ability to create proactive, coordinated plans that promote safety, well-being, and improved outcomes for students. By enhancing our risk-assessment practices, we continue to build a system where students experiencing complex challenges are met with timely, thoughtful, and effective support.

School Mental Health Ontario's Provincial Mental Health Leadership Meeting (PLM)

At the end of April the Superintendent of Education and Mental Health Lead will be representing Huron-Perth District School Board at SMH-ON's Spring Provincial Leadership Meeting. Our Mental Health Lead will be co-presenting three key system resources with the Avon Maitland District School Board Mental Health Lead at the upcoming two-day, in-person Provincial Mental Health Leadership Meeting (PLM):

- Sexual Violence Support Guide

- Huron Perth Mental Health Crisis and Suicide Response Protocol
- Huron Perth Tragic Event Support Team Framework

These presentations will showcase our Board's leadership in coordinated response, trauma-informed practice, and student safety. In addition, our Superintendent will attend the PLM to support this work and strengthen alignment between system leadership and school-level implementation. The PLM brings together Mental Health Leadership Teams from across Ontario to deepen our shared commitment to student mental health and well-being. This spring's gathering focuses on strengthening leadership at the system, school, and classroom levels, with key areas including:

- Supporting students requiring more intensive mental health interventions
- Leadership and practice exchange through Ignite sessions
- Trauma-sensitive system and school leadership
- #HearNowON: Student voices on mental health
- Identity-affirming school mental health leadership
- A provincial Gallery Walk highlighting leadership in school mental health
- Planning ahead to 2026–2027

Participation in this provincial community of practice directly supports our Board's ongoing efforts to enhance consistency, build staff capacity, and strengthen system-level structures that promote student well-being. The learning and collaboration from this event will continue to inform our strategic priorities and reinforce our commitment to safe, supportive, and responsive learning environments.

EXPERIENTIAL LEARNING PROGRAMS IN SECONDARY

Careers in Skilled Trades Webinar: On April 1, the Board hosted Dr. Jon Callegher (Executive Director of Job Talks) an online session for parents focusing on job satisfaction in trades, emerging AI-related professions, and Ontario Youth Apprenticeship Program (OYAP) pathways.

Stratford Home & Leisure Show: On April 11-12, St. Anne's students and teachers showcased learning opportunities. Activities included children building wooden toolboxes and construction students creating a picnic table and plasma-cut fireplace for prizes. Grade 8 students also practiced for the upcoming Skills Ontario competition.

Skills Ontario Truck: A mobile unit visited St. Mary's (Apr 13), St. James (Apr 14), and the Stratford Rotary Complex (Apr 15–17), providing Grade 6 and secondary students hands-on experience with 10 different skill sets.

Conestoga College Electrical & Plumbing Program (Apr 14–17): Grade 8 students from Perth County participated in half-day sessions led by college instructors to gain introductory trades experience.

Skilled Trades & Pathway Event: Grade 7 students engaged with 15 industry-standard trades, while Grade 8 and 10 students explored 17 pathway destinations and 10 agricultural opportunities in partnership with AgScape Ontario.

St. Anne's CSS Pathways Event (Apr 15): Approximately 50 Grade 10 Career Studies students interacted with organizations like AgScape to explore future career options.

Women in Skilled Trades Event (Apr 15): Over 30 female mentors provided demonstrations and held a roundtable dinner for students and parents to discuss apprenticeships and underrepresented career fields.

Specialized Training & Industry Presentations

- Bruce Power Presentation (Apr 17): St. Anne's CSS students learned about nuclear energy careers, including engineering, operations, and skilled trades.
- First Aid / CPR Training (Apr 20–23): 45 SHSM students at St. Anne's CSS earned mandatory certifications over two sessions.
- Festival School of Hair Presentation (Apr 21): Arts & Culture SHSM students at St. Michael CSS participated in a specialized industry presentation.
- Growers Pesticide Safety Course (Apr 22): Agriculture & Environment SHSM students at St. Michael CSS completed this essential safety certification.

Manufacturing & Entrepreneurship

- HMA Manufacturing Tours (Apr 27 & 29): Careers classes toured local facilities via the Huron Manufacturers Association to gain exposure to the manufacturing sector.
- Fanshawe HVAC Program (Apr 27): Two OYAP students began their Level 1 HVAC training.
- Business / Entrepreneurship Trip (Apr 29): Students from both St. Anne's and St. Michael Catholic Secondary Schools traveled to Toronto for marketing workshops with the Blue Jays and SHSM certifications.
- "Jill of All Trades" Event (Apr 30): Four St. Anne's CSS students attended Fanshawe College for hands-on workshops showcasing various trade opportunities.

OYAP Level 1 Programs: 14 students across the district participated in plumbing, electrical, and HVAC programs at Conestoga and Fanshawe Colleges.

Dual Credit Programs: Students earned credits through Lambton, Conestoga, and Fanshawe Colleges in fields ranging from Criminology and Paramedicine to Digital Photography.

SHSM Promotion: Teachers conducted Grade 10 class visits throughout the month to assist with course selections and promote the Specialist High Skills Major program.

DIGITAL TOOLS TO SUPPORT LEARNING

Artificial Intelligence: Secondary Student Summit & Parent Information Night

The Board recently hosted an Artificial Intelligence (AI) summit at both St. Anne's and St. Michael Catholic Secondary Schools featuring guest speaker Giancarlo Brotto. In the days leading up to the event, teachers worked with students to explore the potential opportunities this technology may offer alongside its important ethical and moral implications. The summit featured interactive student presentations at each school, a corporate training session for CEC staff focused on optimizing workflows, and an evening session for parents and caregivers, all designed and delivered from a Catholic perspective. It was a wonderful way for our entire community to engage with the future of AI in a thoughtful and informed way.

Cyber Safety Learning Resources

In today's increasingly connected world, students and educators rely on technology more than ever. This makes it essential to equip our school communities with the knowledge and tools to protect themselves online. The Ministry of Education has provided the Board with project funds through the Project Plan for Cyber Safety Learning Resources. To maximize the impact of the project funds, the Huron-Perth Catholic District School Board is actively establishing a purchasing consortium with other Ontario Catholic District School Boards. By pooling our financial resources and sharing access across boards, we can stretch our funding significantly further, allowing us to acquire premium, multi-year resources that might otherwise exceed an individual board's budget.

FACILITIES AND HEALTH AND SAFETY

Joint Health and Safety Committee Meeting

The Joint Health and Safety Committee met at the CEC on April 8, 2026. Items discussed including the following:

- On-line Reporting Tool Training and H&S Representative Training
- eBase Reporting, Incident Reporting and Safe School Incident Reporting, Messaging and Reporting Timelines
- Walkie Talkies
- Terms of Reference
- Monthly and Annual Inspections
- Ministry of Labour Updates

Annual Health and Safety Week

Annual Health and Safety Week is May 4 - May 9, 2026 with the National Day of Mourning on April 28, 2026.

Facilities Services Update

With the cold weather now behind us, Facilities Services is shifting focus toward seasonal priorities, including yard clean-up and preventive maintenance of key building components. These efforts are essential in ensuring our buildings remain safe, efficient, and ready for the warmer months ahead.

Capital Planning

Over the past several months, significant effort has been dedicated to planning for capital projects, ensuring they align strategically with the Ministry of Education's condition assessment schedule. This proactive approach ensures we are fully prepared for the upcoming summer construction cycle. Notably, the St. Mary's (Listowel) project is progressing well; site services are complete, and with structural steel and masonry now erected, we are ramping up for a productive summer phase.

RECOMMENDATION

THAT the Huron-Perth Catholic District School Board receives the Board Highlights for April for information.
--

Special Education Advisory Committee (SEAC)
March 9, 2026 – 4:00 p.m.

MINUTES

SEAC Members Present:

Kelly Boudreau (Community Living St. Marys), Matt McPhee (Community Living Central Huron), Emily Branje (Facile Futures), Brenda Mason (Stratford Children's Services), Dana Bozzato (Huron Perth Centre), Doris Barkley (Autism Ontario), Jill Plookhaar (Family Services Perth Huron)

Board Trustee: Mary Helen Van Loon

Guest:

Board Office Staff Present:

Tara Boreham, Jessica Langan, Vanessa Yeats, Reanna Desroches, Rhonda Regier, Megan Delcourt

Regrets:

Julie Welch (Community Services Coordination Network), Sandra McLaren (Community Living Stratford & Area), Veronica Kolkman (Huron Perth Public Health)

Quorum: *Achieved* (Minimum 6 of 10 voting members required)

1. Opening Prayer, Welcome & Introductions

Meeting Started: 4:00 pm

2. Approval of Agenda & Minutes

2.1 Approval of February 2026 Minutes

Approved: Matt McPhee

Seconded: Emily Branje

THAT the SEAC approves the meeting minutes of the February 2026 meeting.

Carried.

2.2 Approval of March 2026 Agenda

Approved: Mary Helen Van Loon

Seconded: Brenda Mason

THAT the SEAC approves the agenda of the February 2026 meeting.

Carried.

3. Business Arising from Minutes

Nothing to report.

4. Correspondence

Nothing to report.

5. Agency Reports

5.1 *Trustee Report*

Trustee Mary Helen expressed appreciation for the committee's diverse representation and commitment to student success. On February 25, the Board hosted Minister Thompson and MPP Ray at the Catholic Education Centre. The event included a performance by St. Patrick's kindergarten students and a presentation by superintendents regarding strategic goals in math, literacy, and attendance.

Key discussions with the provincial representatives included transportation, addressing the impact of recent snow days and the decision-making process behind school closures, and staffing shortages, highlighting the critical need for more Educational Assistants (EAs) and Early Childhood Educators (ECEs). The group discussed potential collaborations with colleges and universities to improve program accessibility, including expanded co-op opportunities to support both schools and childcare centres.

The meeting was a valuable opportunity to advocate for the specific needs of our rural community and maintain a positive, open dialogue with government officials.

5.2 *Facile Futures*

Emily noted that the previously mentioned webinar series is approaching. Additionally, Facile Futures has partnered with Perth County agencies on the Voices program to develop a workshop tentatively scheduled for May. This session will support families of students in grades 7 and 8 as they begin planning for the future and exploring how to maximize their school years to build a fulfilling life. More details will be shared as planning progresses.

5.3 *Community Living St. Marys*

Nothing to report at this time.

5.4 *Community Living Central Huron*

Matt reported that last month's fundraising lunch was a significant success, serving over 900 meals. The agency is currently shifting focus to upcoming spring events, including preparations for Community Living Month in May, which features the annual Gerber Daisy sale. Additionally, planning is underway for the yearly golf tournament in June.

5.5 *Huron Perth Public Health*

Nothing to report at this time.

5.6 *Community Living Stratford & Area*

Nothing to report at this time.

5.7 *Autism Ontario*

Doris shared that World Autism Awareness Day is April 2. She recently met with families at a community event where a local teenager expressed interest in student advocacy. Doris

reiterated her availability to visit schools of any grade level to facilitate sensitivity exercises that help students celebrate neurodiversity. She also highlighted the excellent resources available online for teachers, EAs, and support workers.

During the report, Doris and Mary Helen discussed how schools handle instruction during inclement weather. Tara clarified that while schools usually remain open even when buses are cancelled, it is not a direct "remote learning" model. Instead, it is a hybrid approach where teachers provide programming and activities via the Learning Management System (LMS) for students staying home in elementary.

In response to a question from Mary Helen regarding booking school visits, Doris noted that she can be reached directly via email or through the school board. She reflected on her positive experiences working with students at St. Patrick's in Kinkora, emphasizing that her age-appropriate presentations are designed to be fun and engaging for all students.

5.8 *Huron Perth Centre*

Dana provided an update on the centre's current and upcoming evidence-based programs. The Circle of Security parenting program remains a core service, focusing on attachment and relationship building to help parents navigate student behaviours. This program is offered in partnership with several local agencies, including Kids First, ensuring strong facilitator capacity across Huron and Perth counties.

The centre continues to expand its clinical capacity through staff training in Cognitive Behaviour Therapy (CBT) and Dialectical Behaviour Therapy (DBT). DBT is currently a primary resource for youth over age 12 within intensive programming, specifically supporting those facing significant challenges with emotional and behavioural regulation.

Additionally, staff are beginning intensive training for SNAP (Stop Now and Plan). This evidence-based intervention will enhance intensive services provided at the centre, in the community, or within client homes. Dana and Tara have also discussed the potential for SNAP to overlap with school-based day treatment programming. The centre aims to work closely with community partners to build awareness of these expanded service options over the coming months.

5.9 *Stratford Children Services*

Brenda announced the opening of the new wellness centre, located at the Children's Aid Society. The facility recently hosted a tour for Huron-Perth Catholic District School Board Director, Karen Tigani, and serves as a hub for play and art therapy. In partnership with CAS, the wellness centre will host groups utilizing the Circles curriculum and Zones of Regulation, as well as music therapy.

The team is currently collaborating with the Student Mental Health Team and Kristen Wilson (Huron Perth CAS) to identify and address specific family training needs. Additionally, the agency is hosting three Master's level interns, with three more arriving this summer. Brenda noted that the expanded space has been instrumental in fostering these successful community collaborations.

5.10 *CSCN*

Nothing to report at this time.

5.11 Family Services Perth Huron

Nothing to report at this time.

6. Information Reports

6.1 PPM 140 - Megan Delcourt & Jessica Langan

Megan Delcourt and Jessica Langan led a comprehensive "ASD Reboot" presentation centered on PPM 140, explaining that this session mirrors the recent professional development provided to principals and special education teachers. The goal was to ensure the committee is fully aligned with the Ministry of Education's mandate, which requires school boards to integrate Applied Behavioural Analysis (ABA) into the programming for students with Autism Spectrum Disorder. While the directive focuses on ASD, the presenters highlighted that these ABA methods serve as a "Tier 1" universal benefit for all students. They introduced the board's Universal Supports Checklist and an online portal featuring video modules, emphasizing that schools are expected to have these foundational habits, like visual schedules and timers, firmly in place before escalating to more intensive supports.

The presentation walked through the specific requirements of PPM 140, starting with the necessity of formal transition planning for everything from daily classroom shifts to major life changes. It was noted that ABA isn't just a suggestion; it must be written into the Individual Education Plan (IEP) and used across all settings, whether a student is in a specialized or a regular classroom. A significant portion of the discussion focused on the *how* of the programming: using positive reinforcement for skill acquisition and the mandatory collection of data to track progress. They stressed that if the data shows a student isn't meeting their goals, the program must be changed. Finally, they touched on the vital importance of *generalization*, explaining that a skill isn't truly learned until a student can perform it independently across different environments, such as using a washroom in the community rather than just the one at school. The session concluded with a reminder that the Ministry monitors these practices closely and the Huron-Perth Catholic team remains dedicated to meeting these expectations through consistent habit-building and educator support.

7. New Business

No new business at this time.

8. Future Meetings

Next SEAC Meeting - Monday April 20th 2026 at 4:00pm

9. Adjournment

Motion to end meeting was made by: Emily Branje

Meeting adjourned: Brenda Mason

Ended: 5:00 pm

Equity, Diversity, Inclusion and Anti-Racism (EDIAR) Committee Meeting
November 11, 2025 at 4:30 pm

Minutes

Present: Chair, Superintendent Tara Boreham, Trustee Jim McDade, Natanael Mateus-Ruiz, Caroline Thuss, Leroy Hibbert, Faye Hickey, Joshua Pagan, Jayden L., Mackena V. and Wendy Tapsoba
Absent: Ralindee M.

Recording Secretary: Kerri Catalan

1.1. Attendance and Introductions

Noted Above

1.2. Approval of the Agenda

Moved by: Trustee Jim McDade

Seconded by: Natanael Mateus-Ruiz

THAT the EDIAR Committee approves the agenda of the EDIAR Meeting of November 11, 2025

Carried

1.3. Declaration of Interest

None

1.4. Approval of EDIAR Meeting Minutes

Moved by: Natanael Mateus-Ruiz

Seconded by: Caroline Thuss

THAT the EDIAR Committee approves the agenda of the EDIAR Meeting of EDIAR Meeting of June 17, 2025

Carried

1.1. Business Arising from the Minutes

2.1 Superintendent Boreham presented:

- The EDIAR Terms of Reference for Review
- The EDIAR 2025-2026 Work Plan
- Workshops, Professional Learning and Professional Development Days planned for the year.
- EDIAR Update Report

2.4 SACSS Student Representative Report

- There has been a small increase in teachers using the My Place in this World resource to enhance their current curriculum delivery (World History, World Religions are just a couple of examples).
- Many teachers are inviting Josh Pagan, Indigenous Graduation coach, into their classes to share his expertise (physical education, English).
- Christin Dennis came to speak to all five World Religion classes on October 15 and shared knowledge including the symbolism & importance around the Sun Dance.
- SACSS held the annual Remembrance Day assembly on November 10 to include our veterans as guests, and during the assembly the following were highlighted: Canada's First Black Battalion, Indigenous contribution, the contribution of women in the war.

SMCSS Student Representative Report

- The Multi-Cultural Club proposed hosting a cultural fair designed to celebrate diversity through interactive activities, including a global "listening party" and a bake sale. To visualize the community's heritage, they plan to display a world map where students can place pins representing their countries of origin.

4. Dates for meetings- if buses are not running - we will cancel or move to online

- January 13, 2026
- April 14, 2026
- June 16, 2026

Adjournment - 5:30

Catholic Parent Involvement Committee Meeting #1
Tuesday, October 21, 2025 at 6:00 pm
MINUTES

Location: Catholic Education Centre, Dublin

Present:

Senior Administration: Tara Boreham, Superintendent of Education,
CPIC Members: Deanna Lowry, Jen Masselis, Emily Hendriks, Sherri Downey, Kacsha Mcleod, Shaun Kelly, Erin Marshall, April Eilers, Melanie Levinson, Amanda Linton, Janelle Muir-Phillips and Sandra Murphy

Guests: Sarah Devereaux, Manager of Finance

Regrets: Trustee Sue Muller

Quorum: Yes

Recording Secretary: Kerri Catalan, Executive Assistant

1. Opening Business

1.1. Opening Prayer/Introductions-Superintendent Boreham

1.2. Review of Membership and Bylaws of the Committee-Superintendent Boreham

1.3. Elections for 2025-2026 Chair and Co-chair-Superintendent Boreham

Chair - Jim Walsh

Co-Chair - Kasha McLeod

1.4. Attendance and Welcome – Chair

- Conflict of Interest
No one declared a conflict of interest

1.5. Approval of the Agenda – Chair

Moved by: Jen Masselis

Seconded by: Deanna Lowry

That the agenda be accepted as is.

Carried

1.6. Approval of the CPIC Meeting Minutes – June 10, 2025

Moved by: April Eilers

Seconded by: Melanie Levinson

That the Catholic Parent Involvement Committee approves the meeting minutes of the Tuesday June 10, 2025

Carried

2. Reports and Discussion Items

Discussion item:

Shaun K. noted that at the June CPIC meeting, he raised a concern that when the System Track and Field event was cancelled by the Board, that the Board should have had a solution to continue with this event. Superintendent Boreham explained that the Board made the decision because the St. Anne's Catholic District School Board track was not complete. The Board explored all possible alternative venues and solutions; however, none were viable. It was decided that each school would need to host their own track and field event for the 2024-2025 school year.

2.1. Manager of Finance - Sarah Devereaux

Action Item: Fundraising policy to be shared at next Leaders Learner Council along with the Pro Grant memo and letters. Send the School Generated Funds policy and the slide deck to all CPIC members.

2.2. Director's Report – Superintendent Boreham

September/October Events at our Schools

- Back-to-school Masses and liturgies were held across the Board to start the academic year.
- Book fairs were hosted at various school sites.
- The Board officially welcomed eight international students from Spain and Japan to St. Anne's and St. Michael Catholic Secondary Schools.
- Elementary Soccer tournaments were held in Huron and Perth Counties.
- System-wide Cross Country events were successfully held at SACSS and St. Joseph's (Clinton).

School System Support

- Staffing Additions: The Board hired two Literacy Resource teachers, two Math Resource teachers, an Indigenous Support Teacher, and a French Second Language Support teacher (40% FTE).
- Special Education teachers completed training for the Empower (Tier 3) reading intervention program.
- Literacy screening has commenced - this screening is reported to parents. This helps with our planning. Reading Intervention programs include Empower, Corrective Reading and Lexia.

Mental Health and Wellbeing

- Social workers provided direct support for students transitioning back to the classroom.
- Student attendance initiative is being continued (October was Attendance Awareness month)

Professional Development

- When Faith Meets Pedagogy Conference in Toronto on October 23-24 (18 secondary students and 2 chaplains attended)
- Professional Development October 10, 2025
 - Elementary Teachers, SERTS, DECE at all locations
 - AM - School-Based Faith Day/Strategic Plan Review
 - PM - Progress Report Card Writing
 - Elementary Educational Assistants
 - PM- Virtual Learning Opportunity
 - Secondary Teachers, Secondary Educational Assistants
 - AM/PM - Artificial Intelligence
 - Exploring mandatory learning in the Ontario curriculum on AI and digital literacy, including learning about cyber security, EDSTA / Bill 194, and pedagogical use cases

New Teacher Induction Program (NTIP)

The Board welcomed 19 new teachers. They have received orientation and mentorship this past week led by our Learning Coordinators. Some topics covered include, Classroom Management, Curriculum Instructions, Assessment, Evaluation and Reporting.

Parents Reaching Out Grant

Parent engagement funding is provided to each school to support parent engagement activities. The PRO grant funding supports initiatives that identify and address local parent needs and/or remove barriers that prevent parents and families from participating and engaging fully in their children's learning. Each elementary school has been allocated \$500 and secondary schools received \$750. The Principal is encouraged to work with the school council to determine the best use of the funds.

2.3. Board Report - Trustee Sue Muller - no report at this time

2.4. Parent's Update – All

CPIC members provided positive reports on leadership and community engagement, highlighting several successful open houses and a significant increase in meeting attendance at Catholic School Advisory Council, with some groups even seeing grandparents participate. Fundraising remains a primary focus for CSAC, including activities such as greenhouse partnerships, local bakery sales, and the use of donation forms. These funds are being prioritized for outdoor enhancements, including sun shelters, playground equipment like tricycles, "Digger Land" kits, and garden spaces. Funds are also being used for resources such as STEM kits and gym media packages. Several groups are also focusing their budgets on providing student experiences, specifically covering the costs for bussing, skating trips, and community Christmas lunches. It was noted that the processing of Vulnerable Sector Checks (VSCs) is currently delaying the onboarding of several new volunteers.

3. Future Meetings, Events and Resources

- Strategic Plan 2024-2027 - found on the Board website
- CPIC Upcoming School Year Meeting Schedule (virtual/in-person):
Wednesday, January 21, 2026
Wednesday, March 25, 2026
Wednesday, June 3, 2026

4. Closing Business

- Adjournment at 9:10 p.m.
- Closing Prayer – Tara Boreham

Catholic Parent Involvement Committee Meeting #2
Wednesday, January 21, 2026 at 6:00 pm
MINUTES

Location: Catholic Education Centre, Dublin

Present:

Senior Administration: Tara Boreham, Superintendent of Education

Trustee: Sue Muller

CPIC Members: Emily Hendriks, Janelle Muir-Phillips, Sandra Murphy, James Walsh and Jenny Masselis

Guest: Christine Dale, Learning Co-ordinator

Regrets: Sherri Downey, Brianna Flynn, Amanda Linton, Melanie Levinson, Kacsha McLeod, Shaun Kelly, Erin Marshall and April Eilers

Recording Secretary: Kerri Catalan, Executive Assistant

1. Opening Business

1.1 Introductions-Superintendent Boreham

1.3. Attendance and Welcome – Chair, Jim Walsh

- Conflict of Interest
No one declared a conflict of interest.

1.4. Approval of the Agenda – Chair, Jim Walsh

Moved by: Emily Hendriks

Seconded by: Trustee Muller

That the agenda be accepted as is.

Carried.

1.5. Approval of the CPIC Meeting Minutes – October 21, 2025

Moved by: Emily Hendriks

Seconded by: Jenny Masselis

That the Catholic Parent Involvement Committee approves the meeting minutes of Wednesday, October 21, 2025.
Carried.

2. Reports and Discussion Items

2.1. Board Report - Trustee Sue Muller

Trustee Muller provided highlights from the recent Ontario Catholic School Trustees' Association (OCSTA) conference. Key focus areas included:

- Discussions on the integration and impact of Artificial Intelligence in education.
- Strengthening the vital partnerships between schools and local parishes.
- Monitoring Bill 33 and its potential implications for the future of school trustee roles.
- Reviewing student-led video presentations and refining Parent Communication Protocols.

2.2. Director's Report – Superintendent Boreham

Faith & Equity

- Feast of St. André Bessette (Jan 7): Commemorated through specialized prayer and student learning activities.
- Week of Prayer for Christian Unity (Jan 18–25): Schools utilized curated resources to promote ecumenical reflection.
- Holocaust Remembrance Day (Jan 27): Educational resources were distributed via the January 19 Monday Memo to ensure meaningful commemoration.
- Liturgical Season: Preparations are underway for Ash Wednesday (Feb 18) to mark the beginning of Lent.

Student Programming & Athletics

- Skilled Trades: Grade 8 students participated in hands-on learning days hosted by St. Anne's Catholic Secondary School (SACSS).
- Athletics: Both secondary schools successfully hosted the regional Bordenball tournament.
- Literacy: The dedicated Literacy Team is currently conducting school-wide screenings across all elementary sites.

Wellness & Key Dates

Mental Health: The MH Team developed resources for Bell Let's Talk Day (Jan 21) to support student and staff well-being.

- Academic Calendar:
 - Jan 23: Secondary School Exams begin.
 - Feb 13: Elementary Report Cards issued.

- Feb 16: Family Day (No School).

2.3. EQAO Presentation - Christine Dale, Learning Co-Ordinator

2.4. School Council & Community Updates

Parent representatives from various schools (SJ, JS, SH, SAL, and SPK) reported high levels of engagement despite a winter of inclement weather:

- Fundraising: Most schools are transitioning from successful Christmas campaigns (Cheese/Poinsettias/Charcuterie boards) to planning for Shrove Tuesday and Spring Fling events.
- Facilities: A maintenance issue regarding volleyball equipment at Sacred Heart was flagged for administrative review.
- Engagement Funds: Parent engagement money is being effectively utilized for guest speakers (e.g., Leroy Hibbert) and supplemental learning materials.

3. Future Meetings, Events and Resources

3.1 Events and Resources

- Catholic Education Week - May 3-8, 2026
- CEW Mass - Monday, May 4, 5pm, Dublin

3.2 CPIC Upcoming School Year Meeting Schedule

- Wednesday, March 25, 2026
- Wednesday, June 3, 2026

4. Closing Business

- Adjournment at 7:15 pm
- Closing Prayer-Superintendent Boreham



REPORT TO THE HURON-PERTH CATHOLIC DISTRICT SCHOOL BOARD

Prepared by: Sarah Devereaux, Superintendent of Business and Treasurer
Presented to: The Huron-Perth Catholic District School Board
Date: April 27, 2026
Submitted by: Karen Tigani, Director of Education and Secretary

FACILITY PROJECT APPROVALS (VARIOUS)

Public Session

BACKGROUND

School Condition Improvement (SCI) funding is intended to help school boards address the identified renewal needs from the Ministry of Education's School Condition Assessment Program. SCI funding is allocated in proportion to a school board's total assessed renewal needs. The Board's 2025-26 allocation is \$2,654,986 and is based on the 2017 Ministry assessments.

Reports related to the Ministry assessments completed in 2025 have not yet been received. Projects funded under this program must support the overall objective of addressing facility renewal needs. Due to the scope and size of SCI projects, they are usually completed during the summer months.

DEVELOPMENT

The following facility capital projects are planned to begin during the 2025-26 school year. These projects will be funded through the SCI allocation.

1. Precious Blood School - Roof Replacement

The Ministry conducted facility assessments in 2017 and identified the need to re-roof east sections of the school. This area of roofing is twenty four years old. POW Architecture was authorized to prepare a tender package for this project. The tender package was advertised in the Daily Commercial News.

The tender closed on April 8, 2026 at 2:00 p.m. A tender report from POW Architecture is attached. Six (6) prices were received however one was deemed informal. It is recommended that Keller Roofing & Sheet Metal Inc. be awarded this contract in the amount of \$549,180.00 including HST. The roof deck replacement project will be completed during the summer months.

2. Our Lady of Mount Carmel School - Roof Replacement

The Ministry conducted facility assessments in 2017 and identified the need to re-roof the gym section of the school. This area of roofing is twenty four years old. POW Architecture was authorized to prepare a tender package for this project. The tender package was advertised in the Daily Commercial News.

The tender closed on April 8, 2026 at 2:00 p.m. A tender report from POW Architecture is attached. Six (6) prices were received however one was deemed informal. It is recommended that Smith-Peat Roofing & Sheet Metal Ltd. be awarded this contract in the amount of \$203,225.98 including HST. The roof replacement project will be completed during the summer months.

3. St. Anne's CSS Secondary School - Roof Replacement

The Ministry conducted facility assessments in 2017 and identified the need to re-roof south sections of the school. This area of roofing is twenty four years old. POW Architecture was authorized to prepare a tender package for this project. The tender package was advertised in the Daily Commercial News.

The tender closed on April 8, 2026 at 2:00 p.m. A tender report from POW Architecture is attached. Six (6) prices were received however one was deemed informal. It is recommended that Smith-Peat Roofing & Sheet Metal Ltd. be awarded this contract in the amount of \$462,273.96 including HST. The roof replacement project will be completed during the summer months.

4. Jeanne Sauvé School - Roof Replacement

The Ministry conducted facility assessments in 2017 and identified the need to re-roof north sections of the school. This area of roofing is twenty four years old. POW Architecture was authorized to prepare a tender package for this project. The tender package was advertised in the Daily Commercial News.

The tender closed on April 8, 2026 at 2:00 p.m. A tender report from POW Architecture is attached. Six (6) prices were received. It is recommended that Atlas-Apex Roofing (London) Inc. be awarded this contract in the amount of \$204,810.24 including HST. The roof replacement project will be completed during the summer months.

5. St. Joseph's School, Stratford - Roof Replacement

The Ministry conducted facility assessments in 2017 and identified the need to re-roof south sections of the school. This area of roofing is twenty four years old. POW Architecture was authorized to prepare a tender package for this project. The tender package was advertised in the Daily Commercial News.

The tender closed on April 8, 2026 at 2:00 p.m. A tender report from POW Architecture is attached. Six (6) prices were received however one was deemed informal. It is recommended that Keller Roofing & Sheet Metal Inc. be awarded this contract in the amount of \$491,550.00 including HST. The roof replacement project will be completed during the summer months.

6. Jeanne Sauvé School - Lighting Replacement

The Ministry conducted facility assessments in 2017 and identified the need to replace the lighting in the south sections of the school. DMDS Design Services was authorized to prepare a tender package for this project. The tender package was advertised on the Construction Associations Link2Build site.

The tender closed on April 14, 2026 at 2:00 p.m. A tender report from DMDS Design Services is attached and five (5) prices were received. It is recommended that Feltz Design Build Limited. be awarded this contract in the amount of \$312,097.75 including HST. The lighting replacement project will be completed during the summer months.

RECOMMENDATION

THAT the Huron-Perth Catholic District School Board awards the Precious Blood School roof replacement project to Keller Roofing & Sheet Metal Inc. for a total amount of \$549,180.00 including HST.

THAT the Huron-Perth Catholic District School Board awards the Our Lady of Mount Carmel School roof replacement project to Smith-Peat Roofing & Sheet Metal Ltd. for a total amount of \$203,225.98 including HST.

THAT the Huron-Perth Catholic District School Board awards the St. Anne Secondary School roof replacement project to Smith-Peat Roofing & Sheet Metal Ltd. for a total amount of \$462,273.96 including HST.

THAT the Huron-Perth Catholic District School Board awards the Jeanne Sauve School roof replacement project to Atlas-Apex Roofing (London) Inc. for a total amount of \$204,810.24 including HST.

THAT the Huron-Perth Catholic District School Board awards the St. Joseph School, Stratford roof replacement project to Keller Roofing & Sheet Metal Inc. for a total amount of \$491,550.00 including HST.

THAT the Huron-Perth Catholic District School Board awards the Jeanne Sauve School lighting replacement project to Feltz Design Build Limited for a total amount of \$312,097.75 including HST.



Sabrina Vastag, OAA, MRAIC, B.Arch Sci., M.Arch.
Michelle Lester, OAA Lic.Tech., Dip.Arch.Tech.

April 9, 2026

PRECIOUS BLOOD CATHOLIC ELEMENTARY SCHOOL ROOF AREAS C, D & F
Project No.: 25-16-0096

TENDER REPORT

This project was issued to the six prequalified roofing contractors. All six roofing contractors submitted, however, one was deemed informal. The following five prices were received. All prices are HST inclusive.

Flynn Canada Ltd.	\$ 651,319.57
Smith-Peat Roofing & Sheet Metal Ltd.	\$ 615,017.19
Semple Gooder Roofing Corporation	\$ 580,255.00
Atlas-Apex Roofing (London) Inc.	\$ 570,704.24
Keller Roofing & Sheet Metal Inc.	\$ 549,180.00

Keller Roofing & Sheet Metal Inc. has successfully completed projects for the Huron- Perth Catholic District School Board and for this office. We therefore recommend that the Board award this contract to Keller Roofing & Sheet Metal Inc. for the Base Bid in the amount of \$549,180.00.

Respectfully submitted

POW ARCHITECTURE INC.

Michelle Lester, OAA Lic.Tech., Dip.Arch.Tech.
Architectural Designer, General Manager



Sabrina Vastag, OAA, MRAIC, B.Arch Sci., M.Arch.
Michelle Lester, OAA Lic.Tech., Dip.Arch.Tech.

April 9, 2026

OUR LADY OF MOUNT CARMEL CATHOLIC ELEMENTARY SCHOOL ROOF AREA B
Project No.: 25-16-0097

TENDER REPORT

This project was issued to the six prequalified roofing contractors. All six roofing contractors submitted, however, one was deemed informal. The following five prices were received. All prices are HST inclusive.

Simple Gooder Roofing Corporation	\$ 255,154.00
Keller Roofing & Sheet Metal Inc.	\$ 241,413.20
Flynn Canada Ltd.	\$ 235,125.88
Atlas-Apex Roofing (London) Inc.	\$ 220,513.85
Smith-Peat Roofing & Sheet Metal Ltd.	\$ 203,225.98

Smith-Peat Roofing & Sheet Metal Ltd. has successfully completed projects for the Huron-Perth Catholic District School Board and for this office. We therefore recommend that the Board award this contract to Smith-Peat Roofing & Sheet Metal Ltd. for the Base Bid in the amount of \$203,225.98.

Respectfully submitted

POW ARCHITECTURE INC.

Michelle Lester, OAA Lic.Tech., Dip.Arch.Tech.
Architectural Designer, General Manager



Sabrina Vastag, OAA, MRAIC, B.Arch.Sci., M.Arch.
Michelle Lester, OAA Lic.Tech., Dip.Arch.Tech.

April 9, 2026

ST. ANNE'S CATHOLIC SECONDARY SCHOOL ROOF AREA N
Project No.: 25-16-0098

TENDER REPORT

This project was issued to the six prequalified roofing contractors. All six roofing contractors submitted, however, one was deemed informal. The following five prices were received. All prices are HST inclusive.

Flynn Canada Ltd.	\$ 616,117.81
Atlas-Apex Roofing (London) Inc.	\$ 508,484.18
Keller Roofing & Sheet Metal Inc.	\$ 500,544.80
Semple Gooder Roofing Corporation	\$ 489,629.00
Smith-Peat Roofing & Sheet Metal Ltd.	\$ 462,273.96

Smith-Peat Roofing & Sheet Metal Ltd. has successfully completed projects for the Huron-Perth Catholic District School Board and for this office. We therefore recommend that the Board award this contract to Smith-Peat Roofing & Sheet Metal Ltd. for the Base Bid in the amount of \$462,273.96.

Respectfully submitted

POW ARCHITECTURE INC.

Michelle Lester, OAA Lic.Tech., Dip.Arch.Tech.
Architectural Designer, General Manager



Sabrina Vastag, OAA, MRAIC, B.Arch Sci., M.Arch.
Michelle Lester, OAA Lic.Tech., Dip.Arch.Tech.

April 9, 2026

JEANNE SAUVE CATHOLIC ELEMENTARY SCHOOL STRATFORD ROOF AREA E
Project No.: 25-16-0099

TENDER REPORT

This project was issued to the six prequalified roofing contractors. All six roofing contractors submitted, and the following six prices were received. All prices are HST inclusive.

Flynn Canada Ltd.	\$ 263,178.13
LaFleche Roofing Limited	\$ 222,169.30
Keller Roofing & Sheet Metal Inc.	\$ 220,350.00
Smith-Peat Roofing & Sheet Metal Ltd.	\$ 214,914.70
Semple Gooder Roofing Corporation	\$ 210,858.00
Atlas-Apex Roofing (London) Inc.	\$ 204,810.24

Atlas-Apex Roofing (London) Inc. has successfully completed projects for the Huron- Perth Catholic District School Board and for this office. We therefore recommend that the Board award this contract to Atlas-Apex Roofing (London) Inc. for the Base Bid in the amount of \$ 204,810.24.

Respectfully submitted

POW ARCHITECTURE INC.

Michelle Lester, OAA Lic.Tech., Dip.Arch.Tech.
Architectural Designer, General Manager



Sabrina Vastag, OAA, MRAIC, B.Arch Sci., M.Arch.
Michelle Lester, OAA Lic.Tech., Dip.Arch.Tech.

April 9, 2026

ST. JOSEPH CATHOLIC ELEMENTARY SCHOOL STRATFORD ROOF AREAS A, C & D
Project No.: 25-16-0100

TENDER REPORT

This project was issued to the six prequalified roofing contractors. All six roofing contractors submitted, however, one was deemed informal. The following five prices were received. All prices are HST inclusive.

Flynn Canada Ltd.	\$ 817,663.48
Atlas-Apex Roofing (London) Inc.	\$ 562,850.74
Smith-Peat Roofing & Sheet Metal Ltd.	\$ 540,950.21
Semple Gooder Roofing Corporation	\$ 532,682.00
Keller Roofing & Sheet Metal Inc.	\$ 491,550.00

Keller Roofing & Sheet Metal Inc. has successfully completed projects for the Huron- Perth Catholic District School Board and for this office. We therefore recommend that the Board award this contract to Keller Roofing & Sheet Metal Inc. for the Base Bid in the amount of \$491,550.00.

Respectfully submitted

POW ARCHITECTURE INC.

Michelle Lester, OAA Lic.Tech., Dip.Arch.Tech.
Architectural Designer, General Manager

RECAPITULATION SHEET						Date: 2026.04.08	
PRECIOUS BLOOD ROOF AREA C, D & F						Project # 25-16-0096	
for the Huron Perth Catholic District School Board							
	ATLAS-APEX	FLYNN	KELLER	LAFLECHE	SEMPLÉ GOODER	SMITH PEAT	
Base Bid:	\$505,048.00	\$576,389.00	\$486,000.00		\$513,500.00	\$544,263.00	
HST	\$65,656.24	\$74,930.57	\$63,180.00	Informal	\$66,755.00	\$70,754.19	
Total	\$570,704.24	\$651,319.57	\$549,180.00		\$580,255.00	\$615,017.19	
Bid Bond & Agreement to Bond	✓	✓	✓		✓	✓	
Starting Date	✓	✓	✓		✓	✓	
Completion Date	✓	✓	✓		✓	✓	

RECAPITULATION SHEET						Date: 2026.04.08	
OUR LADY OF MOUNT CARMEL ROOF AREA B						Project # 25-16-0097	
for the Huron Perth Catholic District School Board							
	ATLAS-APEX	FLYNN	KELLER	LAFLECHE	SEMPLÉ GOODER	SMITH PEAT	
Base Bid:	\$195,145.00	\$208,076.00	\$213,640.00		\$225,800.00	\$179,846.00	
HST	\$25,368.85	\$27,049.88	\$27,773.20	Informal	\$29,354.00	\$23,379.98	
Total	\$220,513.85	\$235,125.88	\$241,413.20		\$255,154.00	\$203,225.98	
Bid Bond & Agreement to Bond	✓	✓	✓		✓	✓	
Starting Date	✓	✓	✓		✓	✓	
Completion Date	✓	✓	✓		✓	✓	

RECAPITULATION SHEET						Date: 2026.04.08	
ST. ANNE'S ROOF AREA N						Project # 25-16-0098	
for the Huron Perth Catholic District School Board							
	ATLAS-APEX	FLYNN	KELLER	LAFLECHE	SEMPLÉ GOODER	SMITH PEAT	
Base Bid:	\$449,986.00	\$545,237.00	\$442,960.00		\$433,300.00	\$409,092.00	
HST	\$58,498.18	\$70,880.81	\$57,584.80	Informal	\$56,329.00	\$53,181.96	
Total	\$508,484.18	\$616,117.81	\$500,544.80		\$489,629.00	\$462,273.96	
Bid Bond & Agreement to Bond	✓	✓	✓		✓	✓	
Starting Date	✓	✓	✓		✓	✓	
Completion Date	✓	✓	✓		✓	✓	

RECAPITULATION SHEET						Date: 2026.04.08	
JEANNE SAUVE ROOF AREA E						Project # 25-16-0099	
for the Huron Perth Catholic District School Board							
	ATLAS-APEX	FLYNN	KELLER	LAFLECHE	SEMPLÉ GOODER	SMITH PEAT	
Base Bid:	\$181,248.00	\$232,901.00	\$195,000.00	\$196,610.00	\$186,600.00	\$190,190.00	
HST	\$23,562.24	\$30,277.13	\$25,350.00	\$25,559.30	\$24,258.00	\$24,724.70	
Total	\$204,810.24	\$263,178.13	\$220,350.00	\$222,169.30	\$210,858.00	\$214,914.70	
Bid Bond & Agreement to Bond	✓	✓	✓	✓	✓	✓	
Starting Date	✓	✓	✓	✓	✓	✓	
Completion Date	✓	✓	✓	✓	✓	✓	

RECAPITULATION SHEET						Date: 2026.04.08	
ST. JOSEPH ROOF AREAS A, C, & D						Project # 25-16-0100	
for the Huron Perth Catholic District School Board							
	ATLAS-APEX	FLYNN	KELLER	LAFLECHE	SEMPLÉ GOODER	SMITH PEAT	
Base Bid:	\$498,098.00	\$723,596.00	\$435,000.00		\$471,400.00	\$478,717.00	
HST	\$64,752.74	\$94,067.48	\$56,550.00	Informal	\$61,282.00	\$62,233.21	
Total	\$562,850.74	\$817,663.48	\$491,550.00		\$532,682.00	\$540,950.21	
Bid Bond & Agreement to Bond	✓	✓	✓		✓	✓	
Starting Date	✓	✓	✓		✓	✓	
Completion Date	✓	✓	✓		✓	✓	

April 15, 2026

TO
Huron-Perth Catholic District School Board
Mr. Pat Varallo
Manager, Facilities Services

**Jeanne Sauve CES Lighting Replacement (#26-002)
Tender Report**

Mr. Varallo,

This letter serves to summarize the process for the aforementioned project.

Background

As part of the ongoing facilities upgrades for the Huron-Perth Catholic District School Board (HPCDSB), DMDS Limited was retained to prepare drawings and specifications suitable for tender for the subject project.

Scope Summary

The design mandate was to remove and replace the existing T8 Fluorescent lighting with new, update lighting controls for occupancy sensors having dimming and on/off capabilities and replace the old T-bar suspended ceiling assembly in the corridor areas.

Preparations and Procedures

The tender package was posted at the Construction Associations Ling2Build site, and the tender package was made available to all interested General Contractors.

Submissions

The following table summarizes the results that were received prior to the specified closing time:

Contractor	Contract Price	HST
Bronnenco Construction Ltd.	\$298,800.00	\$38,844.00
SDI Builders 2010 Ltd.	\$297,000.00	\$38,610.00
Elgin Contracting & Restoration Ltd.	\$293,000.00	\$38,090.00
Wayne & Harold Smith Construction Ltd.	\$284,900.00	\$37,037.00
Feltz Design Build Ltd.	\$276,192.70	\$35,905.05

Completeness and Arithmetic

The bidders were required to submit a bid package which included the 00300 Tender form, Tender Deposit (certified cheque / bank draft or bid bond), agreement to bond and proof of insurance. Each bid package received included the requested information.

Qualifications or Conditions

The HST amount on Feltz's 00300 Tender Form is incorrectly indicated. However, this error does not affect the Total Value of Contract. The Total Value of Contract shown on their submission is correct.

Recommendations / Conclusions

It is our experience that Feltz Design Build Limited have successfully completed projects for the HPCDSB. We therefore recommend that the Huron-Perth Catholic District School Board award this contract to Feltz Design Build Limited for the total amount of **\$312,097.75** (Contract Price + HST).

If you have questions or require any additional information, please do not hesitate to contact our office.

Sincerely,

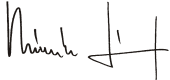

Jozsef Meszaros
DMDS Ltd.

TENDER SUMMARY

Jeanne Sauve CES Lighting Replacement

26-002

Huron-Perth Catholic School Board

4/14/2026

	Bronnenco	Elgin	Feltz	SDI	Smith			
Signed	yes	yes	yes	yes	yes			
Sealed	yes	yes	yes	yes	yes			
Addendae (1)	yes	yes	yes	yes	yes			
Security Deposit	yes	yes	yes	yes	yes			
Project Security	yes	yes	yes	yes	yes			
Proof of Insurance	yes	yes	yes	yes	yes			
Contract Price	\$298,800.00	\$293,000.00	\$276,192.70	\$297,000.00	\$284,900.00			
HST	\$38,844.00	\$38,090.00	\$35,905.05	\$38,610.00	\$37,037.00			
Total Value	\$337,644.00	\$331,090.00	\$312,097.75	\$335,610.00	\$321,937.00			
<u>Subtrades:</u>								
Electrical	Pfaff	Pfaff	Pfaff	Pfaff	Pfaff			
<u>Rates:</u>								
Site Super	\$95.00	\$98.00	\$78.00	\$98.75	\$86.00			
Tradesman	\$105.00	\$90.00	\$68.00	\$78.65	\$80.00			
<u>Alternate Prices</u>								
	none	none	none	none	none			
<u>Separate Prices</u>								
	none	none	none	none	none			

Actual Contract Price **\$276,192.70**
HST \$35,905.05
\$312,097.75



REPORT TO THE HURON-PERTH CATHOLIC DISTRICT SCHOOL BOARD

Prepared by: Sarah Devereaux, Superintendent of Business and Treasurer
Presented to: The Huron-Perth Catholic District School Board
Date: April 27, 2026
Submitted by: Karen Tigani, Director of Education and Secretary

ANNUAL DRINKING WATER REPORT FOR THE PERIOD APRIL 1, 2025 TO MARCH 31, 2026

Public Session

BACKGROUND

The Safe Drinking Water Act, Ontario Regulation 170/03 (Drinking Water Systems) outlines the responsibilities for operators and owners of drinking water systems serving designated facilities, which include schools. The Huron-Perth Catholic District School Board has three (3) schools which do not have a municipal residential drinking water system.

DEVELOPMENT

Per Ontario Regulation 170/03, annual drinking water reports are provided for the following three (3) Schools:

- St. Patrick's School, Dublin
- St. Columban School, St. Columban
- St. Patrick's School, Kinkora

Nitrates and Nitrites are tested quarterly, and lead is tested annually. The requirement for all other parameters is five (5) years. The testing for these parameters was last completed in 2021/22. Testing results are reflected in the attached reports. Items to note:

- The quarterly testing for nitrates and nitrites, and the annual testing for lead completed this year returned no adverse results.
- There is information posted about drinking water and sodium levels at these school sites.
- There is nothing unusual in these reports and they are presented for information purposes.

The drinking water reports are sent annually to the Ministry of Education and the Ministry of the Environment Conservation and Parks. They are also posted on the Board's website, made available at each school location and brought to the Joint Health and Safety Committee as an information item.

RECOMMENDATION

THAT the Huron-Perth Catholic District School Board receives the Annual Drinking Water Report for the Period April 1, 2025 to March 31, 2026.



260014196

OPTIONAL ANNUAL REPORT TEMPLATE

Drinking-Water System Number:	260014196
Drinking-Water System Name:	St. Patrick's, Dublin
Drinking-Water System Owner:	Huron-Perth Catholic District School Board
Drinking-Water System Category:	Small Non-Municipal Non-Residential
Period being reported:	April 1, 2025 – March 31, 2026

<p><u>Complete if your Category is Large Municipal Residential or Small Municipal Residential</u></p> <p>Does your Drinking-Water System serve more than 10,000 people? Yes [] No []</p> <p>Is your annual report available to the public at no charge on a web site on the Internet? Yes [] No []</p> <p>Location where Summary Report required under O. Reg. 170/03 Schedule 22 will be available for inspection.</p> <div style="border: 1px solid black; height: 100px; width: 100%;"></div>	<p><u>Complete for all other Categories.</u></p> <p>Number of Designated Facilities served:</p> <div style="border: 1px solid black; display: inline-block; padding: 2px 10px;">1</div> <p>Did you provide a copy of your annual report to all Designated Facilities you serve? Yes [X] No []</p> <p>Number of Interested Authorities you report to:</p> <div style="border: 1px solid black; display: inline-block; padding: 2px 10px;">1</div> <p>Did you provide a copy of your annual report to all Interested Authorities you report to for each Designated Facility? Yes [X] No []</p>
---	---

Note: For the following tables below, additional rows or columns may be added or an appendix may be attached to the report

List all Drinking-Water Systems (if any), which receive all of their drinking water from your system:

Drinking Water System Name	Drinking Water System Number
None	

Did you provide a copy of your annual report to all Drinking-Water System owners that are connected to you and to whom you provide all of its drinking water?
 Yes [] No [] N/A [X]



Indicate how you notified system users that your annual report is available and is free of charge.

- Public access/notice via the web**
- Public access/notice via Government Office**
- Public access/notice via a newspaper**
- Public access/notice via Public Request**
- Public access/notice via a Public Library**
- Public access/notice via other method** _____

Describe your Drinking-Water System

The St. Patrick's School, Dublin well was drilled in the summer of 1968 and converted to a pitless unit in the fall of 2000. The well casing is approximately 10 cm in diameter and approximately 66 cm above grade. An ultraviolet disinfection system was installed in August 2002 and was operational by September 2, 2002. As an extra safety measure, chlorine disinfection equipment was also installed. This will allow a small residual disinfectant level throughout the school's plumbing distribution system.

List all water treatment chemicals used over this reporting period

Salt for water softener
Chlorine

Were any significant expenses incurred to?

- Install required equipment
- Repair required equipment
- Replace required equipment

Please provide a brief description and a breakdown of monetary expenses incurred

The annual maintenance contract which includes monthly inspection, chlorine, UV light and sleeve replacement at a cost of \$.4576.50 Other supply costs included DPD test packets, softener salt at a cost of \$603.20
We replaced the Pocket Colorimeter at a cost of \$944.00

Provide details on the notices submitted in accordance with subsection 18(1) of the Safe Drinking-Water Act or section 16-4 of Schedule 16 of O.Reg.170/03 and reported to Spills Action Centre



Incident Date	Parameter	Result	Unit of Measure	Corrective Action	Corrective Action Date
Oct 17/25	Microbial	adverse	1	Flush and retest	Oct20/25
Jan 15/26	Microbial	adverse	9	Flush and retest	Jan 16/26

Microbiological testing done under the Schedule 10, 11 or 12 of Regulation 170/03, during this reporting period.

	Number of Samples	Range of E.Coli Or Fecal Results (min #)-(max #)	Range of Total Coliform Results (min #)-(max #)	Number of HPC Samples	Range of HPC Results (min #)-(max #)
Raw	14	0	0-9	14	<10 - 550
Treated	14	0	0	14	<10 - >2000
Distribution	14	0	0	14	<10 - >2000

Operational testing done under Schedule 7, 8 or 9 of Regulation 170/03 during the period covered by this Annual Report.

	Number of Grab Samples	Range of Results (min #)-(max #)	Unit of Measure	NOTE: For continuous monitors use 8760 as the number of samples.
Turbidity	N/A			
Chlorine	201	0.05-2.10	mg/L	
Fluoride (If the DWS provides fluoridation)	N/A			

Summary of additional testing and sampling carried out in accordance with the requirement of an approval, order or other legal instrument.

Date of legal instrument issued	Parameter	Date Sampled	Result	Unit of Measure
N/A				

Summary of Inorganic parameters tested during this reporting period or the most recent sample results

Parameter	Sample Date	Result Value	Unit of Measure	Exceedance
Antimony	Nov 25/21	ND	ug/L	N
Arsenic	Nov 25/21	ND	ug/L	N
Barium	Nov 25/21	49	ug/L	N
Boron	Nov 25/21	140	ug/L	N
Cadmium	Nov 25/21	ND	ug/L	N
Chromium	Nov 25/21	ND	ug/L	N
*Lead	June 11/24	ND	ug/L	N
Mercury	Nov 25/21	ND	mg/L	N



Selenium	Nov 25/21	ND	ug/L	N
Sodium	Jan 27/22	300000	ug/L	Y
Uranium	Nov 25/21	0.41	ug/L	N
Fluoride	Nov 25/21	1.0	mg/L	N
Nitrite	Mar 12/25	ND	mg/L	N
Nitrate	Mar 12/25	ND	mg/L	N
Lead	June 10/25	ND	mg/L	N
Nitrate	Mar 16/26	ND	mg/L	N

*only for drinking water systems testing under Schedule 15.2; this includes large municipal non-residential systems, small municipal non-residential systems, non-municipal seasonal residential systems, large non-municipal non-residential systems, and small non-municipal non-residential systems

Summary of lead testing under Schedule 15.1 during this reporting period

(applicable to the following drinking water systems; large municipal residential systems, small municipal residential systems, and non-municipal year-round residential systems)

Location Type	Number of Samples	Range of Lead Results (min#) – (max #)	Unit of Measure	Number of Exceedances
Plumbing				
Distribution				

Summary of Organic parameters sampled during this reporting period or the most recent sample results

Parameter	Sample Date	Result Value	Unit of Measure	Exceedance
Alachlor	Nov 25/21	ND	ug/L	N
Atrazine	Nov 25/21	ND	ug/L	N
Des-ethyl atrazine	Nov 25/21	ND	ug/L	N
Atrazine + Desethyl-atrazine	Nov 25/21	ND	ug/L	N
Benzene	Nov 25/21	ND	ug/L	N
Benzo(a)pyrene	Nov 25/21	ND	ug/L	N
Bromoxynil	Nov 25/21	ND	ug/L	N
Carbaryl	Nov 25/21	ND	ug/L	N
Carbofuran	Nov 25/21	ND	ug/L	N
Carbon Tetrachloride	Nov 25/21	ND	ug/L	N
Chlorobenzene	Nov 25/21	ND	ug/L	N
Chlorpyrifos (Dursban)	Nov 25/21	ND	ug/L	N
Diazinon	Nov 25/21	ND	ug/L	N
Dicamba	Nov 25/21	ND	ug/L	N
1,2-Dichlorobenzene	Nov 25/21	ND	ug/L	N
1,4-Dichlorobenzene	Nov 25/21	ND	ug/L	N
1,2-Dichloroethane	Nov 25/21	ND	ug/L	N
1,1-Dichloroethylene	Nov 25/21	ND	ug/L	N
Dichloromethane	Nov 25/21	ND	ug/L	N



2-4 Dichlorophenol	Nov 25/21	ND	ug/L	N
2,4-Dichlorophenoxy acetic acid (2,4-D)	Nov 25/21	ND	ug/L	N
Diclofop-methyl	Nov 25/21	ND	ug/L	N
Dimethoate	Nov 25/21	ND	ug/L	N
Diquat	Nov 25/21	ND	ug/L	N
Diuron	Nov 25/21	ND	ug/L	N
Glyphosate	Nov 25/21	ND	ug/L	N
Guthion (Azinphos-methyl)	Nov 25/21	ND	ug/L	N
Malathion	Nov 25/21	ND	ug/L	N
MCPA	Nov 25/21	ND	ug/L	N
Methylene Chloride (Dichloromethane)	Nov 25/21	ND	ug/L	N
Metolachlor	Nov 25/21	ND	ug/L	N
Metribuzin (Sencor)	Nov 25/21	ND	ug/L	N
Paraquat	Nov 25/21	ND	ug/L	N
Pentachlorophenol	Nov 25/21	ND	ug/L	N
Phorate	Nov 25/21	ND	ug/L	N
Picloram	Nov 25/21	ND	ug/L	N
Polychlorinated Biphenyls(PCB)	Nov 25/21	ND	ug/L	N
Prometryne	Nov 25/21	ND	ug/L	N
Simazine	Nov 25/21	ND	ug/L	N
Temphos	Nov 25/21	ND	ug/L	N
Tetrachloroethylene	Nov 25/21	ND	ug/L	N
2,3,4,6-Tetrachlorophenol	Nov 25/21	ND	ug/L	N
Toluene	Nov 25/21	ND	ug/L	N
Triallate	Nov 25/21	ND	ug/L	N
Trichloroethylene	Nov 25/21	ND	ug/L	N
2,4,6-Trichlorophenol	Nov 25/21	ND	ug/L	N
Trifluralin	Nov 25/21	ND	ug/L	N
Vinyl Chloride	Nov 25/21	ND	ug/L	N

List any Inorganic or Organic parameter(s) that exceeded half the standard prescribed in Schedule 2 of Ontario Drinking Water Quality Standards.

Parameter	Result Value	Unit of Measure	Date of Sample



OPTIONAL ANNUAL REPORT TEMPLATE

Drinking-Water System Number:	260014144
Drinking-Water System Name:	St. Columban School
Drinking-Water System Owner:	Huron-Perth Catholic District School Board
Drinking-Water System Category:	Small Non-Municipal Non-Residential
Period being reported:	April 1, 2025 – March 31, 2026

<p><u>Complete if your Category is Large Municipal Residential or Small Municipal Residential</u></p> <p>Does your Drinking-Water System serve more than 10,000 people? Yes [] No []</p> <p>Is your annual report available to the public at no charge on a web site on the Internet? Yes [] No []</p> <p>Location where Summary Report required under O. Reg. 170/03 Schedule 22 will be available for inspection.</p> <div style="border: 1px solid black; height: 100px; width: 100%;"></div>	<p><u>Complete for all other Categories.</u></p> <p>Number of Designated Facilities served: <input style="width: 50px; text-align: center;" type="text" value="1"/></p> <p>Did you provide a copy of your annual report to all Designated Facilities you serve? Yes [X] No []</p> <p>Number of Interested Authorities you report to: <input style="width: 50px; text-align: center;" type="text" value="1"/></p> <p>Did you provide a copy of your annual report to all Interested Authorities you report to for each Designated Facility? Yes [X] No []</p>
---	---

Note: For the following tables below, additional rows or columns may be added or an appendix may be attached to the report

List all Drinking-Water Systems (if any), which receive all of their drinking water from your system:

Drinking Water System Name	Drinking Water System Number
None	

Did you provide a copy of your annual report to all Drinking-Water System owners that are connected to you and to whom you provide all of its drinking water?
 Yes [] No [] N/A [X]



Indicate how you notified system users that your annual report is available, and is free of charge.

- Public access/notice via the web
- Public access/notice via Government Office
- Public access/notice via a newspaper
- Public access/notice via Public Request
- Public access/notice via a Public Library
- Public access/notice via other method _____

Describe your Drinking-Water System

The St. Columban well was drilled in June of 1966 and has been converted to a pitless unit. It is located approximately 3 meters from the school. The casing is 13 cm in diameter and extends approximately 76 cm above grade. An ultraviolet disinfection system was installed in August 2002 and operational by September 1, 2002. As an extra safety measure, chlorine disinfection equipment was also installed. This will allow a small residual disinfectant level through the school's plumbing system.

List all water treatment chemicals used over this reporting period

Salt for water softener
Chlorine

Were any significant expenses incurred to?

- Install required equipment
- Repair required equipment
- Replace required equipment

Please provide a brief description and a breakdown of monetary expenses incurred

The annual maintenance contract which includes monthly inspection, chlorine, UV light and sleeve replacement at a cost of \$ 4576.50. Other supply costs included DPD test packets, softener salt at a cost of \$ 586.77
We made repairs to the system which included a pump replacement and water softener repairs and piping upgrades for a cost of \$10149.00

Provide details on the notices submitted in accordance with subsection 18(1) of the Safe Drinking-Water Act or section 16-4 of Schedule 16 of O.Reg.170/03 and reported to Spills Action Centre

Incident Date	Parameter	Result	Unit of Measure	Corrective Action	Corrective Action Date



Microbiological testing done under the Schedule 10, 11 or 12 of Regulation 170/03, during this reporting period.

	Number of Samples	Range of E.Coli Or Fecal Results (min #)-(max #)	Range of Total Coliform Results (min #)-(max #)	Number of HPC Samples	Range of HPC Results (min #)-(max #)
Raw	11	0	0	0	
Treated	11	0	0	0	
Distribution	11	0	0	0	

Operational testing done under Schedule 7, 8 or 9 of Regulation 170/03 during the period covered by this Annual Report.

	Number of Grab Samples	Range of Results (min #)-(max #)	Unit of Measure
Turbidity	N/A		
Chlorine	156	0.05 – 2.20	mg/L
Fluoride (If the DWS provides fluoridation)	N/A		

NOTE: For continuous monitors use 8760 as the number of samples.

Summary of additional testing and sampling carried out in accordance with the requirement of an approval, order or other legal instrument.

Date of legal instrument issued	Parameter	Date Sampled	Result	Unit of Measure
N/A				

Summary of Inorganic parameters tested during this reporting period or the most recent sample results

Parameter	Sample Date	Result Value	Unit of Measure	Exceedance
Antimony	Nov 25/21	ND	ug/L	N
Arsenic	Nov 25/21	6.2	ug/L	N
Barium	Nov 25/21	ND	ug/L	N
Boron	Nov 25/21	180	ug/L	N
Cadmium	Nov 25/21	ND	ug/L	N
Chromium	Nov 25/21	ND	ug/L	N
*Lead	June 11/24	ND	ug/L	N
Mercury	Nov 25/21	ND	mg/L	N
Selenium	Nov 25/21	ND	ug/L	N



Sodium	Jan 27/22	110000	ug/L	Y
Uranium	Nov 25/21	0.21	ug/L	N
Fluoride	Jan 27/22	1.8	mg/L	Y
Nitrite	Mar 12/25	ND	mg/L	N
Nitrate	Mar 12/25	ND	mg/L	N
Lead	June 10/25	ND	mg/L	N
Nitrate	Mar 16/26	ND	mg/L	N

*only for drinking water systems testing under Schedule 15.2; this includes large municipal non-residential systems, small municipal non-residential systems, non-municipal seasonal residential systems, large non-municipal non-residential systems, and small non-municipal non-residential systems

Summary of lead testing under Schedule 15.1 during this reporting period

(applicable to the following drinking water systems; large municipal residential systems, small municipal residential systems, and non-municipal year-round residential systems)

Location Type	Number of Samples	Range of Lead Results (min#) – (max #)	Unit of Measure	Number of Exceedances
Plumbing				
Distribution				

Summary of Organic parameters sampled during this reporting period or the most recent sample results

Parameter	Sample Date	Result Value	Unit of Measure	Exceedance
Alachlor	Nov 25/21	ND	ug/L	N
Atrazine	Nov 25/21	ND	ug/L	N
Des-ethyl atrazine	Nov 25/21	ND	ug/L	N
Atrazine + Desethyl-atrazine	Nov 25/21	ND	ug/L	N
Benzene	Nov 25/21	ND	ug/L	N
Benzo(a)pyrene	Nov 25/21	ND	ug/L	N
Bromoxynil	Nov 25/21	ND	ug/L	N
Carbaryl	Nov 25/21	ND	ug/L	N
Carbofuran	Nov 25/21	ND	ug/L	N
Carbon Tetrachloride	Nov 25/21	ND	ug/L	N
Chlorobenzene	Nov 25/21	ND	ug/L	N
Chlorpyrifos (Dursban)	Nov 25/21	ND	ug/L	N
Diazinon	Nov 25/21	ND	ug/L	N
Dicamba	Nov 25/21	ND	ug/L	N
1,2-Dichlorobenzene	Nov 25/21	ND	ug/L	N
1,4-Dichlorobenzene	Nov 25/21	ND	ug/L	N
1,2-Dichloroethane	Nov 25/21	ND	ug/L	N
1,1-Dichloroethylene (vinylidene chloride)	Nov 25/21	ND	ug/L	N
2-4 Dichlorophenol	Nov 25/21	ND	ug/L	N
2,4-Dichlorophenoxy acetic acid (2,4-D)	Nov 25/21	ND	ug/L	N



Diclofop-methyl	Nov 25/21	ND	ug/L	N
Dimethoate	Nov 25/21	ND	ug/L	N
Diquat	Nov 25/21	ND	ug/L	N
Diuron	Nov 25/21	ND	ug/L	N
Glyphosate	Nov 25/21	ND	ug/L	N
Guthian (Azinphos-methyl)	Nov 25/21	ND	ug/L	N
Malathion	Nov 25/21	ND	ug/L	N
MCPA	Nov 25/21	ND	ug/L	N
Methylene Chloride (Dichloromethane)	Nov 25/21	ND	ug/L	N
Metolachlor	Nov 25/21	ND	ug/L	N
Metribuzin (Sencor)	Nov 25/21	ND	ug/L	N
Paraquat	Nov 25/21	ND	ug/L	N
Pentachlorophenol	Nov 25/21	ND	ug/L	N
Phorate	Nov 25/21	ND	ug/L	N
Picloram	Nov 25/21	ND	ug/L	N
Polychlorinated Biphenyls(PCB)	Nov 25/21	ND	ug/L	N
Prometryne	Nov 25/21	ND	ug/L	N
Simazine	Nov 25/21	ND	ug/L	N
Temephos	Nov 25/21	ND	ug/L	N
Tetrachloroethylene	Nov 25/21	ND	ug/L	N
2,3,4,6-Tetrachlorophenol	Nov 25/21	ND	ug/L	N
Toluene	Nov 25/21	ND	ug/L	N
Triallate	Nov 25/21	ND	ug/L	N
Trichloroethylene	Nov 25/21	ND	ug/L	N
2,4,6-Trichlorophenol	Nov 25/21	ND	ug/L	N
Trifluralin	Nov 25/21	ND	ug/L	N
Vinyl Chloride	Nov 25/21	ND	ug/L	N

List any Inorganic or Organic parameter(s) that exceeded half the standard prescribed in Schedule 2 of Ontario Drinking Water Quality Standards.

Parameter	Result Value	Unit of Measure	Date of Sample



OPTIONAL ANNUAL REPORT TEMPLATE

Drinking-Water System Number:	260014183
Drinking-Water System Name:	St. Patrick's, Kinkora
Drinking-Water System Owner:	Huron-Perth Catholic District School Board
Drinking-Water System Category:	Small Non-Municipal Non-Residential
Period being reported:	April 1, 2025 – March 31, 2026

<p><u>Complete if your Category is Large Municipal Residential or Small Municipal Residential</u></p> <p>Does your Drinking-Water System serve more than 10,000 people? Yes [] No []</p> <p>Is your annual report available to the public at no charge on a web site on the Internet? Yes [] No []</p> <p>Location where Summary Report required under O. Reg. 170/03 Schedule 22 will be available for inspection.</p> <div style="border: 1px solid black; height: 100px; width: 100%;"></div>	<p><u>Complete for all other Categories.</u></p> <p>Number of Designated Facilities served: <input style="width: 50px; text-align: center;" type="text" value="1"/></p> <p>Did you provide a copy of your annual report to all Designated Facilities you serve? Yes [X] No []</p> <p>Number of Interested Authorities you report to: <input style="width: 50px; text-align: center;" type="text" value="1"/></p> <p>Did you provide a copy of your annual report to all Interested Authorities you report to for each Designated Facility? Yes [X] No []</p>
---	---

Note: For the following tables below, additional rows or columns may be added or an appendix may be attached to the report

List all Drinking-Water Systems (if any), which receive all of their drinking water from your system:

Drinking Water System Name	Drinking Water System Number
None	

Did you provide a copy of your annual report to all Drinking-Water System owners that are connected to you and to whom you provide all of its drinking water?

Yes [] No [] N/A [X]



Indicate how you notified system users that your annual report is available, and is free of charge.

- Public access/notice via the web
- Public access/notice via Government Office
- Public access/notice via a newspaper
- Public access/notice via Public Request
- Public access/notice via a Public Library
- Public access/notice via other method _____

Describe your Drinking-Water System

The St. Patrick’s School well was drilled in the summer of 1965 and was originally contained in a concrete pit. The well casing has been extended and the former pit has been filled with sand. It is approximately 10 cm in diameter and extends approximately 27 cm above the sand and approximately 66 cm above ground. An ultraviolet disinfection system was installed in August 2002 and operational by September 1, 2002. As an extra safety measure, chlorine disinfection equipment was also installed. This will allow a small residual disinfectant level through the school’s plumbing distribution system. In December 2002, the chemical feeder and retention tank were relocated. The water lines were rerouted so that the chlorine is injected after the water softener and UV lamps. These changes have allowed the system to operate much smoother without alarming. In early December 2009, the cement well pit was removed to below grade. The existing well casing area was re-graded with clean fill and grouting occurred around the exposed well casing to ground level with bentonite. This work was done based on direction from the Ministry of the Environment.

List all water treatment chemicals used over this reporting period

Salt for water softener
Chlorine

Were any significant expenses incurred to?

- Install required equipment
- Repair required equipment
- Replace required equipment

Please provide a brief description and a breakdown of monetary expenses incurred

The annual maintenance contract which includes monthly inspection, chlorine, UV light and sleeve replacement at a cost of \$ 4576.50 Other supply costs included DPD test packets, softener salt at a cost of \$605.97
We replaced the tank at this location at a cost of \$2592.47



Provide details on the notices submitted in accordance with subsection 18(1) of the Safe Drinking-Water Act or section 16-4 of Schedule 16 of O.Reg.170/03 and reported to Spills Action Centre

Incident Date	Parameter	Result	Unit of Measure	Corrective Action	Corrective Action Date

Microbiological testing done under the Schedule 10, 11 or 12 of Regulation 170/03, during this reporting period.

	Number of Samples	Range of E.Coli Or Fecal Results (min #)-(max #)	Range of Total Coliform Results (min #)-(max #)	Number of HPC Samples	Range of HPC Results (min #)-(max #)
Raw	11	0	0	11	<10 – 2000
Treated	11	0	0	11	<10 – 10
Distribution	11	0	0	11	<10 – 10

Operational testing done under Schedule 7, 8 or 9 of Regulation 170/03 during the period covered by this Annual Report.

	Number of Grab Samples	Range of Results (min #)-(max #)	Unit of Measure
Turbidity	N/A		
Chlorine	195	0.05 – 2.20	mg/L
Fluoride (If the DWS provides fluoridation)	N/A		

NOTE: For continuous monitors use 8760 as the number of samples.

Summary of additional testing and sampling carried out in accordance with the requirement of an approval, order or other legal instrument.

Date of legal instrument issued	Parameter	Date Sampled	Result	Unit of Measure
N/A				

Summary of Inorganic parameters tested during this reporting period or the most recent sample results

Parameter	Sample Date	Result Value	Unit of Measure	Exceedance
Antimony	Nov 25/21	ND	ug/L	N
Arsenic	Nov 25/21	4.4	ug/L	N
Barium	Nov 25/21	ND	ug/L	N
Boron	Nov 25/21	110	ug/L	N
Cadmium	Nov 25/21	ND	ug/L	N
Chromium	Nov 25/21	ND	ug/L	N



*Lead	June 13/24	ND	ug/L	N
Mercury	Nov 25/21	ND	mg/L	N
Selenium	Nov 25/21	ND	ug/L	N
Sodium	Jan 27/22	95000	ug/L	Y
Uranium	Nov 25/21	.14	ug/L	N
Fluoride	Jan 27/22	2.3	mg/L	Y
Nitrite	Mar 12/25	ND	mg/L	N
Nitrate	Mar 12/25	ND	mg/L	N
Lead	June 10/25	ND	mg/L	N
Nitrate	Mar 16/26	ND	mg/L	N

*only for drinking water systems testing under Schedule 15.2; this includes large municipal non-residential systems, small municipal non-residential systems, non-municipal seasonal residential systems, large non-municipal non-residential systems, and small non-municipal non-residential systems

Summary of lead testing under Schedule 15.1 during this reporting period

(applicable to the following drinking water systems; large municipal residential systems, small municipal residential systems, and non-municipal year-round residential systems)

Location Type	Number of Samples	Range of Lead Results (min#) – (max #)	Unit of Measure	Number of Exceedances
Plumbing				
Distribution				

Summary of Organic parameters sampled during this reporting period or the most recent sample results

Parameter	Sample Date	Result Value	Unit of Measure	Exceedance
Alachlor	Nov 25/21	ND	ug/L	N
Atrazine	Nov 25/21	ND	ug/L	N
Des-ethyl atrazine	Nov 25/21	ND	ug/L	N
Atrazine + Desethyl-atrazine	Nov 25/21	ND	ug/L	N
Benzene	Nov 25/21	ND	ug/L	N
Benzo(a)pyrene	Nov 25/21	ND	ug/L	N
Bromoxynil	Nov 25/21	ND	ug/L	N
Carbaryl	Nov 25/21	ND	ug/L	N
Carbofuran	Nov 25/21	ND	ug/L	N
Carbon Tetrachloride	Nov 25/21	ND	ug/L	N
Chlorobenzene	Nov 25/21	ND	ug/L	N
Chlorpyrifos (Dursban)	Nov 25/21	ND	ug/L	N
Diazinon	Nov 25/21	ND	ug/L	N
Dicamba	Nov 25/21	ND	ug/L	N
1,2-Dichlorobenzene	Nov 25/21	ND	ug/L	N
1,4-Dichlorobenzene	Nov 25/21	ND	ug/L	N
1,2-Dichloroethane	Nov 25/21	ND	ug/L	N



1,1-Dichloroethylene (vinylidene chloride)	Nov 25/21	ND	ug/L	N
2-4 Dichlorophenol	Nov 25/21	ND	ug/L	N
2,4-Dichlorophenoxy acetic acid (2,4-D)	Nov 25/21	ND	ug/L	N
Diclofop-methyl	Nov 25/21	ND	ug/L	N
Dimethoate	Nov 25/21	ND	ug/L	N
Diquat	Nov 25/21	ND	ug/L	N
Diuron	Nov 25/21	ND	ug/L	N
Glyphosate	Nov 25/21	ND	ug/L	N
Guthion (Azinphos-methyl)	Nov 25/21	ND	ug/L	N
Malathion	Nov 25/21	ND	ug/L	N
MCPA	Nov 25/21	ND	ug/L	N
Methylene Chloride (Dichloromethane)	Nov 25/21	ND	ug/L	N
Metolachlor	Nov 25/21	ND	ug/L	N
Metribuzin (Sencor)	Nov 25/21	ND	ug/L	N
Paraquat	Nov 25/21	ND	ug/L	N
Pentachlorophenol	Nov 25/21	ND	ug/L	N
Phorate	Nov 25/21	ND	ug/L	N
Picloram	Nov 25/21	ND	ug/L	N
Polychlorinated Biphenyls(PCB)	Nov 25/21	ND	ug/L	N
Prometryne	Nov 25/21	ND	ug/L	N
Simazine	Nov 25/21	ND	ug/L	N
Temephos	Nov 25/21	ND	ug/L	N
Tetrachloroethylene	Nov 25/21	ND	ug/L	N
2,3,4,6-Tetrachlorophenol	Nov 25/21	ND	ug/L	N
Toluene	Nov 25/21	ND	ug/L	N
Triallate	Nov 25/21	ND	ug/L	N
Trichloroethylene	Nov 25/21	ND	ug/L	N
2,4,6-Trichlorophenol	Nov 25/21	ND	ug/L	N
Trifluralin	Nov 25/21	ND	ug/L	N
Vinyl Chloride	Nov 25/21	ND	ug/L	N

List any Inorganic or Organic parameter(s) that exceeded half the standard prescribed in Schedule 2 of Ontario Drinking Water Quality Standards.

Parameter	Result Value	Unit of Measure	Date of Sample



REPORT TO THE HURON-PERTH CATHOLIC DISTRICT SCHOOL BOARD

Prepared by: Tara Boreham and Sean McDade, Superintendents of Education
Presented to: The Huron-Perth Catholic District School Board
Date: April 27, 2026
Submitted by: Karen Tigani, Director of Education and Secretary

2.2.8 ASSESSMENT, EVALUATION AND REPORTING OF STUDENT ACHIEVEMENT

Public Session

BACKGROUND

The Huron-Perth Catholic District School (the Board) believes in and is committed to improved student learning through consistent, transparent, equitable, and faith-filled assessment, evaluation, and reporting practices. This framework is deeply rooted in Catholic Social Teaching principles and aligns with the Ontario Ministry of Education's policies, notably *Growing Success* (2010). As part of the policy's evolution, the former procedure has been expanded and moved to the Board's online website to ensure up-to-date accessibility for the entire Catholic school community.

DEVELOPMENTS

The assessment and evaluation framework was developed to integrate the primary purpose of assessment and improving student learning with Catholic values, viewing assessment as a sacred trust and a redemptive process that leads to growth, restoration, and hope. The development of this policy establishes the following key areas:

Catholic Foundations: Assessment practices are designed to be redemptive and use an asset-based lens, focusing on what students know and can do while nurturing the Ontario Catholic School Graduate Expectations.

Guiding Principles & Equity: The policy embeds the Seven Fundamental Principles of *Growing Success* (2010) and emphasizes equity, inclusion, and student voice, ensuring all students have opportunities to demonstrate learning regardless of socio-economic status, culture, identity, or learning profile.

Professional Judgment: The framework supports ongoing professional learning to strengthen educators' professional judgment, emphasizing evidence gathered over time and across multiple contexts.

Roles and Responsibilities: Clear expectations have been developed, tasking the Superintendent of Education with keeping online procedures up-to-date, while Principals and teachers are responsible for adhering to and communicating these procedures to parents/caregivers and students.

The policy has been reviewed and is now presented for the consideration of the Board of Trustees. The revised policy will be available for vetting and comment by the community in advance of the policy coming to the Board for approval in May.

RECOMMENDATION

THAT the Huron-Perth Catholic District School Board receives policy 2.2.8 Assessment, Evaluation and Reporting of Student Achievement.



HURON-PERTH CATHOLIC

District School Board

Assessment, Reporting and Evaluation of Student Achievement

Adopted:	August 25, 2003	Policy #:	P 2.2.8.
Revised:	June 17, 2019	Policy Category:	2.2. School Program

BELIEF STATEMENT

The Huron-Perth Catholic District School Board believes that every learner is created in the image and likeness of God, possessing unique gifts and infinite potential. Our approach to assessment, evaluation, and reporting is a sacred trust, deeply rooted in Catholic faith and Catholic Social Teaching principles. Through this lens, we fulfill our mission to nurture the Ontario Catholic School Graduate Expectations, guiding our students to reach their God-given potential within a Christ-centered environment.

POLICY STATEMENT

The Huron-Perth Catholic District School Board is committed to improving student learning through consistent, transparent and equitable assessment, evaluation and reporting practices. This is conducted in a faith-centred environment of inclusive Catholic education and aligned with the philosophy and direction of the Ministry of Education.

The primary purpose of assessment and evaluation is to improve student learning. Accordingly, principals and teachers uphold, recognize and affirm our Catholic values in daily practices by:

- respecting the dignity of all students;
- incorporating differentiated learning experiences;
- providing multiple opportunities for students to demonstrate their learning;
- using assessment practices that are redemptive in nature;
- fostering life-long learners and recognizing the God-given capacity of each person to learn and grow throughout their lives;
- reflecting the holistic nature of assessment which integrates the learning and faith development of the student;
- reporting student achievement with clear, specific and timely communication of ongoing progress to all parents/guardians and students.

POLICY STATEMENT

The Huron-Perth Catholic District School Board is committed to improving student learning through consistent, transparent, equitable, and faith-filled assessment, evaluation, and reporting practices. These practices are grounded in Catholic Teachings and align with the philosophy, policies, and direction of the Ontario Ministry of Education, including *Growing Success (2010)*.

Assessment, evaluation, and reporting are integral to effective instruction and are conducted within a Christ-centred learning environment that honours the dignity, uniqueness, and God-given potential of every learner.

ROLES AND RESPONSIBILITIES

The Superintendent of Education will ensure that up-to-date Board Assessment, Evaluation, and Reporting Procedures are posted on the Board [Website](#).

Principals will communicate that the Board Procedures are available to all members of the Catholic school community through the School [Website](#).

EXPECTATIONS

Principals and teachers will adhere to the Board Assessment, Evaluation, and Reporting Procedures.

Parents and students will be informed of the Board Assessment, Evaluation, and Reporting Procedures through appropriate communication tools.

PURPOSE AND CATHOLIC FOUNDATIONS

The primary purpose of assessment and evaluation is to improve student learning. In our Catholic context, assessment is not merely a measure of knowledge, but a process that leads to growth, restoration, and hope.

In fulfilling our professional responsibilities, principals and teachers are called to uphold Catholic values in all assessment practices by:

- **Respecting Dignity:** Respecting the inherent dignity of every student and recognizing the holistic nature of learning, integrating intellectual, spiritual, social, emotional, and moral development.
- **Engaging in Redemptive Practice:** Using assessment practices that are redemptive in nature, allowing for mistakes, growth, and the opportunity to demonstrate improvement.
- **Using an Asset-Based Lens:** Our evaluation process focuses on identifying and communicating what students know and can do with respect to the overall curriculum expectations, rather than focusing on deficits in their understanding.
- **Embedding the Ontario Catholic School Graduate Expectations:** Ensuring practices reflect the Graduate Expectations and affirm the shared responsibility to nurture learners who are called to transform God's world with wisdom, compassion, and hope.
- **Providing Timely Feedback:** Communicating student achievement and progress clearly, specifically, and in a timely manner to students and parents/guardians in order to improve student understanding and learning.

THE SEVEN FUNDAMENTAL PRINCIPLES

To ensure that assessment, evaluation, and reporting are valid, reliable, and lead to improved learning for all students, educators shall apply the Seven Fundamental Principles outlined in *Growing Success (2010)*. Assessment practices must:

- be fair, transparent, and equitable for all students;
- support students with special education needs, students learning the language of instruction, and students who identify as First Nation, Métis, or Inuit;
- be carefully planned and aligned with curriculum expectations, learning goals, and the strengths, needs, interests, and experiences of students;
- be clearly communicated to students and parents/guardians;
- be ongoing, varied, and administered over time to provide multiple opportunities to demonstrate learning;
- include descriptive feedback that is clear, specific, meaningful, timely and connected to learning goals and success criteria; and
- develop students' capacity for self-assessment, goal setting, and reflection.

EQUITY, INCLUSION, AND STUDENT VOICE

Fairness in assessment and evaluation is grounded in the belief that all students are given the opportunity to demonstrate their learning regardless of socio-economic status, culture, identity, gender, learning profile, or access to resources.

The Board is committed to:

- Implementing inclusive and culturally responsive curriculum and assessment practices;
- Reviewing instructional and assessment resources to identify and address systemic bias; and
- Valuing student voice as an essential component of instructional planning and accurate assessment.

Students must see themselves reflected in the curriculum and have meaningful opportunities to express their understanding in ways that honour their strengths.

PROFESSIONAL JUDGMENT AND CONTINUOUS IMPROVEMENT

Effective assessment and evaluation relies on the professional judgment of educators, informed by evidence of student learning gathered over time and across multiple contexts, with particular emphasis on most recent, most consistent.

The Board supports ongoing professional learning to strengthen assessment practices and ensure alignment with best practices, Catholic values, and Ministry of Education policy.

REFERENCES

FORMER REFERENCES:

- Growing Success: Assessment, Evaluation, and Reporting in Ontario Schools
- Growing Success: The Kindergarten Addendum
- ~~Huron Perth Catholic District School Board Assessment, Evaluation, and Reporting Procedures~~
- Board Policy Equity and Inclusive Education
- Huron-Perth Catholic District School Board Special Education Plan
- Special Education in Ontario Policy and Resource Guide
- Learning for All
- Religious Education: Growing Successfully in Assessment, Evaluation, and Reporting

UPDATED REFERENCES

- *Growing Success: Assessment, Evaluation, and Reporting in Ontario Schools (2010)*
- *Growing Success: The Kindergarten Addendum (2016)*
- *Institute for Catholic Education (2019)*
- *Learning for All (2013)*
- *Renewing the Promise (2018)*
- Huron-Perth Catholic District School Board Equity and Inclusive Education Policy

RESOURCES, APPENDICES AND FORMS:

- [Huron Perth Catholic DSB Assessment, Evaluation, Reporting internal website \(procedures\)](#)
- [Huron Perth Catholic DSB Approved Assessment Tools](#)



REPORT TO THE HURON-PERTH CATHOLIC DISTRICT SCHOOL BOARD

Prepared by: Tara Boreham, Superintendent of Education
Presented to: The Huron-Perth Catholic District School Board
Date: April 27, 2026
Submitted by: Karen Tigani, Director of Education and Secretary

MODIFIED SCHOOL DAY

Public Session

BACKGROUND

The Huron-Perth Catholic District School Board believes that all students have an inherent right to a caring, effective, and inclusive education in a Christ-centred environment. In circumstances where a principal, in consultation with the Superintendent of Education, determines that a modified school day is in the best interest of a student due to the reasons outlined below, a modified school day may be implemented on a temporary basis to allow for the development of appropriate programming and support for the student.

DEVELOPMENTS

A modified day may be considered for a student who is unable to successfully manage the demands of a full instructional day despite the implementation of appropriate school and system-based interventions and supports, such as universal supports, differentiated instruction, individualized programming, Positive Behaviour Support Plans, or Safe Intervention Plans where appropriate. When a student has not responded to these interventions, the principal may consider implementing a modified day based on the following:

- A medical issue documented by a medical practitioner
- Behaviour that impacts the safety of the student or others in the school

A modified school day involves a reduction in the length of the school day, up to and including a full withdrawal from school. A modified day is intended to be a temporary measure and will be subject to regular review, with a plan developed to support the student's return to a full instructional day as soon as appropriate.

The Huron-Perth Catholic District School Board has an administrative procedure to provide a framework for planning and implementing a modified school day for students in both elementary and secondary schools. The revised policy has been available on the website for vetting. No feedback was received and staff are recommending approval of the policy.

RECOMMENDATION

THAT the Huron-Perth Catholic District School Board approves policy 2.2.4 Modified School Day.



HURON-PERTH CATHOLIC

District School Board

Modified School Day

Adopted:	May 25, 2020	Policy #:	P 2.2.4.
Revised:		Policy Category:	2.2. School Program

BELIEF STATEMENT:

The Huron-Perth Catholic District School Board (the Board) affirms the inherent right of all students to a caring, effective, and inclusive education within a Christ-centred environment. Any modified school day plans and administrative procedures must be consistent with Catholic teachings and designed to develop appropriate, individualized support. The Board requires that all such plans prioritize a gradual transition to support full-time attendance, with the express goal of maximizing the student's time at school and achieving a return to a regular, full school day.

POLICY STATEMENT:

Guided by the governance principles of the Board of Trustees and their responsibility to oversee equitable and safe education in Ontario, it is the policy of the Huron-Perth Catholic District School Board to provide individualized accommodations and support to students. A modified day may be considered for a student who is unable to successfully manage the demands of a full instructional day despite the implementation of appropriate school and system-based interventions and supports, such as universal supports, differentiated instruction, individualized programming, Positive Behaviour Support Plans, or Safe Intervention Plans where appropriate.

In circumstances where a medical issue has been documented by a medical practitioner, or when the principal determines that a student's behaviour or presence in the school may be a safety concern for themselves or others, the principal may implement a modified school day on a temporary basis to allow for the development of appropriate programming. A modified school day is defined as a reduction in the length of the school day, up to and including a temporary withdrawal from school.

The process of accommodating a student with a modified day shall be reviewed individually by a School-Based Team (SBT), which will consider parent/guardian input, the student's academic achievement, and the disability-related and/or medical needs of the student. The accommodation process must balance the student's integration and independence with the health and safety of all individuals who are or might be in the school, ensuring a clear plan is developed to eventually return the student to full-time attendance.

Furthermore, to uphold the Board's mandate for provincial accountability and transparency, the Board shall retain data regarding Modified Day Plans, including specific attendance code records and schedules, which must be kept on file for audit purposes as outlined in the Modified School Day Administrative Procedure.

DEFINITIONS:

Modified Day - Is a reduction in the length of the school day up to and including a full exclusion from school.

Temporary Reduced Day - A reduction in the regular (300 minute) instructional day determined at a School-Based Team meeting.

Modified Day Plan - A plan for students who require a gradual transition to support full-time attendance. The goal is to return the student to a regular day as soon as possible.

Temporary Full Exclusion from School on an Emergency Basis - A full exclusion from school. A temporary full exclusion from school.

Exceptional Pupil - A pupil who is identified within the scope of the IPRC process.

School-Based Team (SBT) - the principal (Chair), parent/guardian, SERT, classroom teacher, Special Education Coordinator, school superintendent, appropriate representatives from community-based agencies/service and anyone the principal deems necessary.

OSR - Ontario Student Record

REFERENCES:

- Education Act s. 265 (1) (m) – student exclusions for safety
- Education Act Reg. 298 (3) (1) – reduced length of instructional program for exceptional pupils

RESOURCES, APPENDICES AND FORMS:

- Board Administrative Procedure 2.2.17



REPORT TO THE HURON-PERTH CATHOLIC DISTRICT SCHOOL BOARD

Prepared by: Sean McDade, Superintendent of Education
Presented to: The Huron-Perth Catholic District School Board
Date: April 27, 2026
Submitted by: Karen Tigani, Director of Education and Secretary

CATHOLIC EDUCATION WEEK

Public Session

BACKGROUND

Each year, during the first week of May, we celebrate Catholic Education Week, a meaningful tradition across Ontario's Catholic school boards. We are grateful and honoured to provide exceptional Catholic education. Our schools are communities where joy, peace, hope, and love flourish, grounded in the life-giving message of the Gospel. This special week offers a unique opportunity to highlight the many blessings found within our Catholic school communities.

During Catholic Education Week, we intentionally open our doors wider—welcoming families and guests, sharing the vibrancy of our faith-filled schools, and actively extending the light of Christ into the homes, parishes, and communities we are proud to walk alongside.

This is a time when we joyfully live out our Board's mission. To proclaim the Good News of Jesus through the ways we learn, grow, create, and connect with one another. As a Catholic School Board, we are committed to serving students in partnership with families and parishes by:

- Nurturing a Christ-centred environment
- Providing student-focused learning opportunities
- Supporting the growth of the whole person

DEVELOPMENTS

Pilgrims of Hope: On the Path to Holiness

The 2026 Catholic Education Week theme is "Pilgrims of Hope: On the Path to Holiness". Hope is foundational to our faith. We find hope in God's grace and love. This year's Catholic Education Week, Catholic Education: Pilgrims of Hope: On the Path to Holiness, is inspired by the following:

- The Pilgrims of Hope Jubilee year in 2025, continues to provide us with inspiration to serve the common good and recommit ourselves to prayer, service, and evangelization in 2026 and beyond.
- Under the loving leadership of Pope Leo XIV, this school year continues to be a time to renew the momentum of our Jubilee celebrations by inviting everyone in Catholic education to embrace the journey toward holiness and peace.

- In light of the recent canonization of Blessed Carlos Acutis, the Catholic Education Week theme reflects the Pastoral Letter to Young People issued by the Bishops of Canada in October 2022. The example of young saints, including Saint Carlo Acutis, shows us very vividly, what it means to live as pilgrims on a journey of faith, toward a hope grounded in the unshakeable love of the Risen Jesus. In Ontario's Catholic schools, there is an intentional effort to celebrate the lives of the Saints during Catholic Education Week. Catholic student trustees have been learning about the lives of the Saints and their contributions inform some of the resources available to staff and students on the OCSTA website.
- Our lives as Christians are truly a path toward holiness – becoming, more and more, the people God created us to be. That will look different in each of our lives, but for all of us, we know that it is God's Spirit at work in us who guides us toward holiness: "The Holy Spirit illuminates all believers with the light of hope. He keeps that light burning, like an ever-burning lamp, to sustain and invigorate our lives." (Spes Non Confundit, 3)

In our Catholic school board, we are intentional about aligning this theme with the existing board spiritual theme of "On Fire with the Spirit". We encourage staff and students to consider ways in which they can explicitly celebrate and honour our individual and collective call to love within the existing spiritual theme "On Fire with the Spirit", yet connected to the 2026 Catholic Education Week theme "Pilgrims of Hope: On a Path to Holiness".

Catholic Education Week (CEW) Website

A Huron-Perth Catholic DSB Google site has been updated and is a landing page for all materials that will support Catholic Education Week in our district. Resources from the Ontario Catholic School Trustees Association (OCSTA), along with Board-created resources that support faith-based activities, prayer services, and CEW-themed lessons for K-12 classrooms, can be found there. Our goal is to ensure educators have timely access to CEW resources and can embed them throughout their lessons all week.

Catholic Education Week System Mass

All staff, students, families and parishioners of the Huron-Perth Catholic District School Board are welcome to celebrate Mass as a community on Monday, May 4th at St. Patrick's Catholic Church in Dublin. Mass will be celebrated by Rev. Innocent Ibeh. Music and other liturgical ministries are being organized and led by staff and students from across the district. We are pleased that close to 50 students from St. Joseph's School, Clinton and St. Boniface School will lead us in song under the direction of teachers Ms. Kristyn Elgi and Ms. Natalie Steeper. Following Mass, there is a reception in the church hall where all are welcome to gather for some light refreshments and fellowship. Several Catholic awards will be presented at this Mass too, including the St Mother Teresa Faith in Action Awards, the Order of St André Bessette and recognition of the recipients of the Trustees Catholic Student Leadership Awards.

Faith and Art

All schools have been asked to submit student-created artwork that either captures our Board theme, "On Fire with the Spirit," or the Catholic Education Week theme, "Pilgrims of Hope: On the Path to Holiness". Selected pieces will be framed and displayed in the church hall for the reception after the Catholic Education Week Mass, and then will be moved over to the Catholic Education Centre, where they will be displayed for one year.

Families of Parishes Messages

As in the past, parish bulletins will include a message provided by the Ontario Catholic School Trustees Association (OCSTA) to be included in the various print and e-bulletins used by parishes in our deanery. The message highlights the partnership between the home, school and parish families and invites ongoing engagement with and support for our Catholic schools.

Individual School Activities

Schools across the district will recognize Catholic Education Week in their own way through a variety of activities that include school Mass and prayer liturgies, Christian Meditation, Living Rosary, retreats, and community celebrations. Many of these activities are made possible through the “Blaze the Trail” faith funding that has allowed schools to invest in faith formation opportunities tailored to their school community’s needs.

RECOMMENDATION

THAT the Huron-Perth Catholic District School Board receives the Catholic Education Week report for information.



REPORT TO THE HURON-PERTH CATHOLIC DISTRICT SCHOOL BOARD

Prepared by: Tara Boreham, Superintendent of Education
Presented to: The Huron-Perth Catholic District School Board
Date: Monday, April 27, 2026
Submitted by: Karen Tigani, Director of Education and Secretary

STUDENT ATTENDANCE REPORT

Public Session

BACKGROUND

Improved student attendance has been established by the Huron-Perth Catholic District School Board as a key system goal, directly aligning with our 2024-2027 Strategic Plan, *On Fire with the Spirit: Awaken, Illuminate, Rejoice*. This foundational priority is deeply rooted in our Catholic mission and values, reflecting our unwavering commitment to fostering environments where all students are supported to be present, fully engaged, and successful. This document serves as a formal progress update to the Board of Trustees, demonstrating our dedication to transparency, continuous improvement, and accountability in achieving this critical objective.

DEVELOPMENTS

Attendance Strategy Update-April 2026

Improving student attendance and academic engagement remains a priority that requires a collaborative effort among caregivers, school staff, principals, and the Attendance Counsellor. Our Multi-Tiered System of Support (MTSS) framework continues to guide this work by bringing these partners together to identify and address attendance barriers, raise awareness, and foster a positive school climate that supports student belonging. The District will continue to implement systems to enable early identification and support for students who are at risk of not graduating.

Early Identification and Communication Strategy

The Board has successfully implemented a new referral process, which has been clearly communicated to all administrators and Special Education Resource Teachers (SERTs). This process explicitly encourages the submission and acceptance of persistent absence referrals for students with chronic attendance concerns, enabling early identification and coordinated, proactive interventions designed to strengthen school engagement.

Furthermore, we executed 'Attendance Awareness Month' in October to actively raise awareness among parents and caregivers about the importance of consistent attendance. Our Attendance Counsellor maximized outreach efforts during the Calling All Three-Year-Olds (CATYO) initiative at six elementary schools, utilizing COMPASS data that showed which schools had a reduced rate of student attendance to strategically target outreach locations. The attendance counsellor proceeded by setting up an information booth and distributing pamphlets along with HPCDSB branded materials to promote awareness about the importance of regular attendance.

Progress on Multi-Tiered Attendance Support System:

Tier 1: Promoting Awareness as Foundation

This year, Caregiver Packages were distributed to all Grade 1 families, as age six marks the year when school attendance becomes mandatory. These packages were designed to provide guidance and encouragement and included helpful resources from the Ontario Association for Counselling and Attendance Services (OACAS) and Attendance Works, offering caregivers practical tools to support regular attendance and academic engagement. In collaboration with the Huron Perth Children's Aid Society (HPCAS) and Avon Maitland District School Board (AMDSB), we facilitated another caregiver webinar titled "My Child Does Not Want to Attend School," which provide information about attendance and shared strategies about healthy routines to support student attendance.

Tier 2: Follow-Up Procedures

Principals are actively engaging in school/family meetings and following up with students and families experiencing attendance challenges. Students with persistent absenteeism are being referred to the Attendance Counsellor for additional support. The Attendance Counsellor is using the School Refusal Assessment Scales with both students and caregivers to better understand the underlying functions of school avoidance. Instead of simply labeling the behaviour, the scale identifies the reasons driving a student's reluctance to attend, allowing for more precise and supportive intervention planning. In addition to direct student work, the Attendance Counsellor is coaching administrators and educators on the student's profile, the contributing factors influencing their avoidance, and the evidence-informed strategies that align with the identified function of the behaviour. This includes guiding staff in implementing targeted interventions, such as gradual fear-exposure approaches, relationship-building strategies, predictable routines, and environmental adjustments to help reduce anxiety, increase readiness, and support a successful return to consistent school engagement.

Tier 3: Attendance Counsellor Interventions

To date, the Attendance Counsellor has supported 30 students with persistent absenteeism and 26 students with prolonged absenteeism. Interventions include home visits, one-on-one check-ins, caregiver guidance on routines and sleep hygiene, and referrals to community resources. The attendance counsellor implemented the School Refusal Assessment Scale that was discovered via the Attendance Research project last year. The assessment has helped to better understand each student's unique attendance needs by obtaining perspectives from the student and their caregivers. This has proven effective in better understanding the student within their school, home and community and uncover hidden barriers to better engage and offer individualized interventions.

Benchmark and Strategic Goal

ONSIS reporting indicates that 92.15% of students in Grades 1–8 attended school at least 90% of the time during the 2024–2025 school year. The ONSIS data for 2024–2025 also confirms that several schools have 40% or more of students with 30+ absences. This elevated absence rate is largely explained by our rural geography, where weather-related "grant days," bus cancellations, and transportation disruptions significantly increased total days absent across the year.

ThoughtExchange: Attendance Engagement Summary

To better understand the factors influencing student attendance, the Board and the Attendance Counsellor conducted a system-wide 'ThoughtExchange' survey with students, staff, caregivers, and community partners. The goal was to gather authentic, experience-based insights to guide targeted and effective attendance interventions. We received a total of 1,900 responses across students, staff, caregivers, and community partners, and this high level of engagement demonstrates that these groups see value in contributing their voices to shape how we move forward.

Beginning with students, the responses highlight the key motivators and barriers shaping their daily attendance. Students reported that social connection is their strongest motivator for attending school, with 71% citing socializing and 72% highlighting friendships. Their most common barriers include illness (43%), stress or anxiety (21%), and low motivation (34%). Many students expressed a need for clearer catch-up processes (59%), more consistent support from staff, and more engaging learning experiences. Among students in Grades 4–6, difficulty waking up (39%) and a lack of excitement about school (30%) point to challenges with routine and engagement.

Caregivers emphasized the importance of regular attendance, with 69% rating it as “extremely important” and 76% identifying a very high impact on learning and well-being. They reported illness (85%), weather (38%), extracurricular activities (36%), and mental health (21%) as the most common reasons for absences. Caregivers also expressed a need for clearer guidance on illness-related absences, mental health expectations, and tools to support consistent routines at home.

Staff respondents indicated that they observed predictable attendance patterns, including late arrivals (65%), dips on Mondays and Fridays (41%), and seasonal or weather-related absences (33%). They identified illness (53%), low motivation (47%), extracurricular activities (44%), mental health concerns (37%), and sleep challenges (29%) as key contributors to absenteeism. Staff reported significant academic impacts, with 96% noting that students fall behind when absent, and highlighted disruptions to classroom routines (73%) and peer relationships (68%). They identified a need for stronger communication frameworks, improved collaboration with support staff, and training to support effective attendance-related conversations.

Community partners identified bullying (94%), discrimination (90%), unstable housing, food insecurity, and unmet basic needs as major barriers to student success. They strongly supported the expansion of wrap-around services (87%) and emphasized their role as key partners in co-creating support and improving outreach to disengaged students.

Across all groups, the findings point to a consistent direction: strengthening attendance requires building trusting relationships and a sense of belonging, improving communication and clarity for families, expanding mental health and wellness supports, addressing basic-needs barriers that affect readiness to learn, and ensuring students can re-engage academically after absences through supportive and predictable processes.

Looking Ahead/Recommendation:

The work over the past 2 years, alongside this year’s ‘ThoughtExchange’ data clearly indicates that improving attendance requires strengthening relationships, enhancing communication with families, expanding mental health and wellness supports, and addressing the broader social and structural conditions that influence students’ readiness and ability to attend. Our focus remains on early intervention, caregiver engagement, collaboration and creative approaches to support students in remaining connected to their learning environments. Through these initiatives, we continue to advance the Board’s Strategic Plan by fostering collaboration, raising awareness, and supporting students and families in overcoming attendance barriers.

RECOMMENDATION

THAT the Huron-Perth Catholic District School Board receives the Student Attendance Report for information.



REPORT TO THE HURON-PERTH CATHOLIC DISTRICT SCHOOL BOARD

Prepared by: Sean McDade, Superintendent of Education
Presented to: The Huron-Perth Catholic District School Board
Date: April 27, 2026
Submitted by: Karen Tigani, Director of Education and Secretary

STEM REPORT AND SKILLS UPDATE

Public Session

BACKGROUND

The Huron-Perth Catholic District School Board (HPCDSB) remains committed to providing students with multiple, rich opportunities to develop skills in Science, Technology, Engineering, and Mathematics (STEM). This mandate is deeply rooted in our 2024-2027 Strategic Plan, which emphasizes increasing student participation in inquiry-based activities and high-quality, hands-on technology.

On March 26, 2026, the Board hosted its 3rd Annual District Technological Skills Competition at the Seaforth Agriplex. This event serves as a primary vehicle for achieving our strategic goal of increasing participation in Skills Ontario and ensuring our students consistently place in the top half of the province at competitive levels.

DEVELOPMENTS

Strategic Alignment and Student Achievement

In direct alignment with the strategic theme of Awaken, Illuminate, and Rejoice, the 2026 competition saw a significant expansion in both participation and scope. Building on the success of previous years, approximately 220 students from across the district utilized the Engineering Design Process to compete in technical categories including:

- Established Categories: Robotics, Mechanical Engineering, Green Energy, and Construction.
- New Innovation: This year marked the successful debut of the Landscaping and Horticulture category, further diversifying our experiential learning programs to align with labour market trends.

Integration of Digital Tools and Literacy

The competition showcased the "human-centered" integration of technology. Students applied classroom learning through digital tools such as coding software and programs, reflecting our commitment to equipping classrooms with age-appropriate tools for learning.

Community and Industry Partnerships

The success of the event was bolstered by collaborative efforts between educators, learning coordinators, and community partners. These partnerships are essential to providing a well-rounded and enriching educational experience and fostering a community-wide approach to student success.

Future Planning: The Road to Skills Ontario

The winners from this district-level event will represent the HPCDSB at the Skills Ontario provincial competition in May 2026. Data gathered from this competition will inform future professional learning for teachers and help establish further district benchmarks for technical proficiency. Moving forward, the Board will continue to:

- Expand access to hands-on learning tools to support student engagement.
- Foster a broader diversity of industry partnerships across all STEM fields.
- Utilize instructional coaching to support responsive teaching practices in technology

RECOMMENDATION

THAT the Huron-Perth Catholic District School Board receives the Stem Report and Skills Update report for information.



REPORT TO THE HURON-PERTH CATHOLIC DISTRICT SCHOOL BOARD

Prepared by: Sean McDade, Superintendent of Education
Presented to: The Huron-Perth Catholic District School Board
Date: April 27, 2026
Submitted by: Karen Tigani, Director of Education and Secretary

ARTIFICIAL INTELLIGENCE SUMMIT AND PARENT INFORMATION NIGHT

Public Session

BACKGROUND

The Huron-Perth Catholic District School Board (HPCDSB) remains committed to the strategic integration of Artificial Intelligence (AI) tools in a manner that is responsible, informed, and ethically grounded. Since the adoption of Policy # P 3.2.2, Artificial Intelligence, the Board has ensured that technology remains a tool that supports, rather than replaces, human decision-making and dignity.

This report details the implementation of the district-wide Secondary School AI Summit and accompanying Parent and Caregiver Information Night held on April 9 and 10, 2026. These initiatives fulfill the Board's intentional focus toward broad community engagement and student readiness for a post-secondary landscape increasingly shaped by these technologies.

DEVELOPMENTS

In alignment with the 2024-2027 Strategic Plan, this summit moved beyond basic technical literacy toward meaningful, human-centered integration. By using a faith-informed lens, the programming emphasized that while algorithms can predict the future, they cannot replace a person's God-given purpose.

The two-day event featured international keynote speaker and global strategist Giancarlo Brotto, who addressed students at both secondary schools. The summit focused on:

- Ethical Navigation: Centering AI use around human dignity and Catholic values to ensure technology is used for the common good.
- Discernment Skills: Equipping students with the critical thinking required to respect the sanctity of the person while utilizing digital tools.
- Future-Ready Literacy: Providing hands-on access to global expertise to prepare students for the next chapter of their lives.

Recognizing that parents and caregivers face new challenges in raising tech-savvy children rooted in faith, a dedicated evening session was held on April 9th at St. Michael Catholic Secondary School. This session provided:

- Practical strategies for supporting children in an AI-augmented world.
- Resources for maintaining mental well-being and digital balance.

- A forum for dialogue regarding safety, ethics, and the impact of technology on human connection.

Beyond the student experience, the summit included corporate training sessions for Board departments. These sessions explored how AI can increase operational efficiency, thereby repurposing time for deeper human interactions and relationship-building across the system.

Evidence of Impact: Data Analysis

To measure the effectiveness of the AI Summit and the influence of guest speaker Giancarlo Brotto, the Board conducted pre- and post-presentation surveys among the student body. The following data highlights the shift in student perspective, ethical commitment, and readiness.

1. Growth in Student Preparedness and Discernment

Prior to the summit, many students expressed uncertainty regarding the role of AI in their future careers. Following the session, there was a measurable shift in confidence:

- 33% of students explicitly reported feeling more prepared and informed about the future landscape of work and technology.
- While 16% reported feeling more nervous about automation, qualitative feedback suggests this stems from a new, healthy sense of critical discernment and an understanding of the competitive landscape, a key component of being a Reflective and Creative Thinker.

2. Commitment to Academic Integrity and Catholic Values

A primary goal of the summit was to move students from passive consumption of AI to ethical authorship. When asked how they would change their habits following the speaker's address:

- 23% of participants made a formal commitment to submit original work and ensure AI is not used to generate assignments in their entirety.
- 15% of students committed to actively fact-checking AI-generated content for 'hallucinations' or misinformation, demonstrating a rise in digital literacy and a commitment to truth.

3. Quality and Engagement Metrics

The investment in a high-level international speaker resulted in exceptionally high engagement levels:

- On a scale of 1 to 5, over 80% of students rated the value of the presentation at a 3 or higher, with the majority of responses falling in the 4 ("High Value") and 5 ("Exceptional Value") categories.
- Pre-survey data showed that while students were already using AI for brainstorming and summarizing, the summit successfully pivoted the conversation toward human-centered innovation, where the student remains the primary driver of the creative process.

4. Qualitative Feedback: The Student Voice The impact of the summit is best captured by student reflections recorded in the post-survey:

- "I realized that AI can predict things, but it can't replace my purpose."
- "I feel more confident knowing how to use these tools to help me learn, rather than just having them do the work for me."
- "The talk changed how I see my future job; I need to focus on what makes me human."

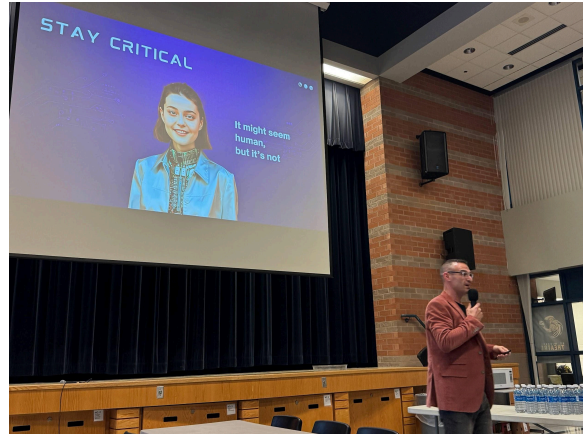
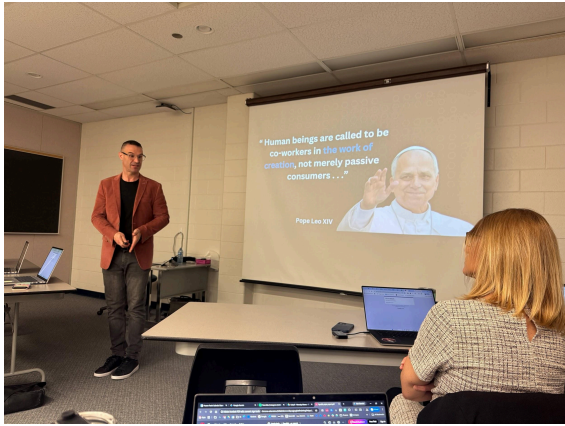

RECOMMENDATION

THAT the Huron-Perth Catholic District School Board receives the Artificial Intelligent Summit and Parent Information Night report for information.



REPORT TO THE HURON-PERTH CATHOLIC DISTRICT SCHOOL BOARD

Prepared by: Dean DeLuca – St. Michael CSS, Stratford
Addison Thuss – St. Anne's CSS, Clinton
Presented to: The Huron-Perth Catholic District School Board
Date: April 27, 2026
Submitted by: Karen Tigani, Director of Education and Secretary

STUDENT TRUSTEES' REPORT Public Session

BACKGROUND

The Huron-Perth Catholic District School Board recognizes that student trustees are an important and valuable voice in representing the interests of the student body at Board Meetings. The Board is committed to providing an opportunity for student voice at the Board table.

Below is a summary highlighting Catholic faith initiatives, academic updates and information about activities and events taking place at each of our secondary schools.

DEVELOPMENTS

Religious/Charitable Events/Accomplishments

St. Michael CSS

- St. Michael CSS celebrated Holy Thursday on April 2 as a school community in prayer with three liturgies led by our chaplain, Natalie.
- Students and staff volunteered at the Community Kitchen on April 16 at St. Joseph Parish. Mr. Damen led staff, students and community members in prayer before students served dinner to them.
- Natalie and Mr. Garrick have an after-school bible study on Wednesdays from 3:00 pm to 4:00 pm. All students and staff are welcome!
- Grade 10s had a NET retreat on April 20 at the Rotary Complex.

St. Anne's CSS

- On April 2, our Lenten project wrapped up by exceeding our goal of raising \$1200.
- We celebrated our Holy Thursday liturgy on April 2.
- Our book club continues reading the book *Diary of Jesus Christ* every Thursday.
- Our chaplain continues to lead a scripture study program on Fridays.
- The Grade 11 retreat is happening on April 28.

Academic Events/Accomplishments

St. Michael CSS

- Selected SHSM students completed a pesticide safety course.
- On April 8, the Grade 10 science classes spent the day learning at Ripley's Aquarium.
- Students in all grades spent time learning about Artificial Intelligence on April 8. Giancarlo Brotto was an informative and engaging speaker who spoke about the benefits and risks associated with AI. He also introduced how a faith lens can help guide how AI impacts our lives as students.
- On April 14, Leroy Hibbert, a consultant for LUSO visited all Grade 9 religion classes and had lunch with the multicultural club.

- Grade 10 students wrote the OSSLT on April 15.
- Students received mid-term report cards on April 23.
- The Grade 10 careers classes explored the pathway event at RBC on April 16 and participated in HMA tours on April 27.
- Students in the business SHSM will spend the day learning about marketing techniques in a hands-on approach in Toronto on April 29.

St. Anne's CSS

- On April 1, Grade 9 and 10 students participated in the Waterloo Math Competition.
- On April 7, Grade 11 HSP3U/3C and HSB4U students attended a presentation from United Way.
- On April 9, Grade 10 students wrote the OSSLT.
- On April 10, students attended an Artificial Intelligence presentation in the cafeteria.
- On April 15, Grade 10 students attended a pathways seminar in Stratford.
- On April 15, we also hosted a music workshop with Jeff Christmas.
- On April 17, a virtual careers presentation from Bruce Nuclear Power Plant was offered to interested students.
- On April 20 and 27, students from the HRE4O classes attended Huronview Nursing and Retirement Home, where they shared fellowship and entertainment (cards, games, and crafts) while actively living their faith in the community.
- From April 21 to 24, SHSM First Aid and CPR training was completed in two groups.
- On April 22, SHSM Agricultural students participated in a trip to the REACH Centre in Clinton.
- On April 22, music students performed at Huronview Retirement Home in Clinton.
- On April 22, all French Immersion students attended a French film.
- On April 23, art students went on an art gallery trip.
- On April 29, SHSM students will participate in an entrepreneurship trip to Toronto.
- A group of female students interested in the trades attended the Jill of All Trades workshop at Fanshawe College.

Athletics/Arts Events/Accomplishments

St. Michael CSS

- The St. Michael CSS concert band participated in the Kiwanis Music Festival on April 9.
- On April 16, our senior badminton team competed at the Huron Perth competition at the Rotary Complex.
- On April 17, our school community participated in a school yard cleanup for Earth day.
- On April 21, our junior badminton team competed at the Huron Perth competition at the Rotary Complex.
- On April 23, some St. Michael CSS students participated in an OFSAA basketball 3-on-3 event in memory of Olivia Rourke, co-founder of Hoops for Hope.
- On Thursday, April 30, St. Michael CSS will host the Tribal Vision Dance Company. This Indigenous, high-energy performing group will educate our students and staff about First Nations culture through dance, music, and storytelling.
- Junior and Senior Boys and Girls Soccer tryouts happened early in the month.
- Artists were asked to create a piece for Catholic Education Week.
- Rehearsals for our spring musical *Grease* continued in preparation for the performance week in early May.
- The junior and senior Envirothon teams participated in preparation workshops for the competition at the Morrison Dam Conservation area on April 1; both teams participated in the regional Envirothon on April 8; the senior team finished 3rd overall.

St. Anne's CSS

- All spring sports are up and running.
- On April 1, the Eco Club attended an Environthon workshop at Morrison Dam.

- On April 8, students in the Eco Club competed in the Environthon competition at Morrison Dam.
- On April 9, the Eagles band attended Kiwanis in Stratford and won.
- On April 16, the Senior Badminton team competed at Huron-Perth in Stratford.
- On April 16 and 17, the Drama Club attended the Dramatic Arts Crossroads Festival in Blyth.
- On April 22, the ARC Club hosted an Earth Day/Wenjack activity in the cafeteria during both junior and senior lunches.

RECOMMENDATION

THAT the Huron-Perth Catholic District School Board receives the Student Trustees' Report for information.



REPORT TO THE HURON-PERTH CATHOLIC DISTRICT SCHOOL BOARD

Prepared by: Sarah Devereaux, Superintendent of Business and Treasurer
Presented to: The Huron-Perth Catholic District School Board
Date: April 27, 2026
Submitted by: Karen Tigani, Director of Education and Secretary

FEBRUARY 28, 2026 FINANCIAL REPORT

Public Session

BACKGROUND

Ontario Regulation 361/10 Audit Committees, Section 9(6) details duties related to the Board's risk Management. To assist the Committee in its role to assess financial risks facing the Board, quarterly financial reports are received by the Board's Audit Committee.

DEVELOPMENT

The quarterly financial report for the period ending February 28, 2026 is attached. At this time, year-to-date expenditures are on track with 48.6% of total budget spent. This statement will be shared with the Audit Committee at a later date.

RECOMMENDATION

THAT the Huron-Perth Catholic District School Board receives the February 28, 2026 Financial Report.

**Huron-Perth Catholic District School Board
2025-26 Financial Report**

September 1, 2025 to February 28, 2026

Summary of Financial Results

	Estimates	Revised Estimates	YTD Actuals	YTD % of Rev Est
Revenue				
Operating Grants	\$ 78,607,851	\$ 78,848,991	\$ 41,800,586	53.0%
Capital Grants	11,341,411	16,328,229	3,026,857	18.5%
Less: Revenue Flowed to DCC	(8,037,449)	(13,026,326)	(1,246,016)	9.6%
Other	1,823,083	2,255,616	1,200,527	53.2%
School Generated Funds	2,155,000	1,800,000	1,097,342	61.0%
Total Revenue	\$ 85,889,896	\$ 86,206,510	\$ 45,879,294	53.2%
Expenditures				
Classroom	\$ 61,016,452	\$ 62,174,906	\$ 30,497,146	49.1%
Other Operating	3,322,192	3,547,914	1,743,545	49.1%
Transportation	7,715,255	7,715,255	3,754,252	48.7%
Pupil Accommodation	11,500,129	10,787,567	4,955,865	45.9%
Other	180,868	180,868	36,968	20.4%
School Generated Funds	2,155,000	1,800,000	916,385	50.9%
Total Expenditures	\$ 85,889,896	\$ 86,206,510	\$ 41,904,162	48.6%
In-Year Surplus (Deficit)	-	-	3,975,133	
Prior Year Accumulated Surplus (Deficit)	7,511,363	7,864,462	7,864,462	
Accumulated Surplus (Deficit)	\$ 7,511,363	\$ 7,864,462	\$ 11,839,595	

Notes:

Revised Estimates

Revenue

- Operating grant increase due to increased enrolment
- Capital grants include prior year carryforwards
- Other includes rentals, REP, tuition, interest, other grants. Increase due to carryforwards and additoinal REP funding since Estimates
- School generated funds estimate reduced in line with prior year actuals

Expenditures

- Classroom reflects additional program expenses due to enrolment increase and carryforwards
- Pupil accomodation decrease from decrease in amortization due to timing of capital projects
- School generated funds estimate reduced in line with prior year actuals

*DCC: Deferred Capital Contributions
REP: Responsive Education Programs*

Actuals

Revenue

- Operating grants and deferred operating revenue recognized throughout the year. Revenue as expected for Q2
- Most capital grants flow as expenses are incurred. Majority of capital projects occur in spring/summer. Revenue as expected for Q2
- Other includes REP & other grants
- Student fees in Q2 School Generated Funds, will align with expenses as year progresses

Expenditures

- Pupil Accom - Amortization for capital increases Q3 & 4 due to timing
- Other - annual debt financing expense not incurred until Q3
- Total expenses as expected for Q2

*PPE: Personal Protective Equipment
YTD: Year to Date*

**Huron-Perth Catholic District School Board
2025-26 Financial Report**

September 1, 2025 to February 28, 2026

Summary of Enrolment

FTE	Estimates	Revised Estimates	In-Year Change	
			#	%
Elementary				
JK -3	1,629.0	1,669.5	40.5	2.5%
4-8	1,728.0	1,722.0	(6.0)	-0.3%
Total Elementary	3,357.0	3,391.5	34.5	1.0%
Secondary <21				
Pupils of the Board	1,181.0	1,196.5	15.5	1.3%
Other Pupils	8.0	7.0	(1.0)	0.0%
Total Secondary	1,189.0	1,203.5	14.5	1.2%
Total	4,546.0	4,595.0	49.0	1.1%
Secondary High Credit	15.0	13.4	(1.6)	-10.7%

Summary of Staffing

FTE	Estimates	Revised Estimates	In-Year Change	
			#	%
Classroom Teachers (Including Resource)				
	289.1	289.4	0.3	0.1%
Educational Assistants				
	100.0	101.0	1.0	1.0%
Early Childhood Educators				
	24.0	25.0	1.0	4.2%
School Admin & Support				
	43.8	43.7	(0.1)	-0.2%
Coordinators, Technicians & Paraprofessionals				
	42.1	41.1	(1.0)	-2.4%
Operations & Maintenance				
	37.7	37.3	(0.4)	-1.1%
Board Admin				
	27.3	26.8	(0.5)	-1.8%
Senior Admin				
	5.0	5.0	-	0.0%
Total	569.0	569.2	0.2	0.0%

Changes in Enrolment: Actual vs. Revised Estimates

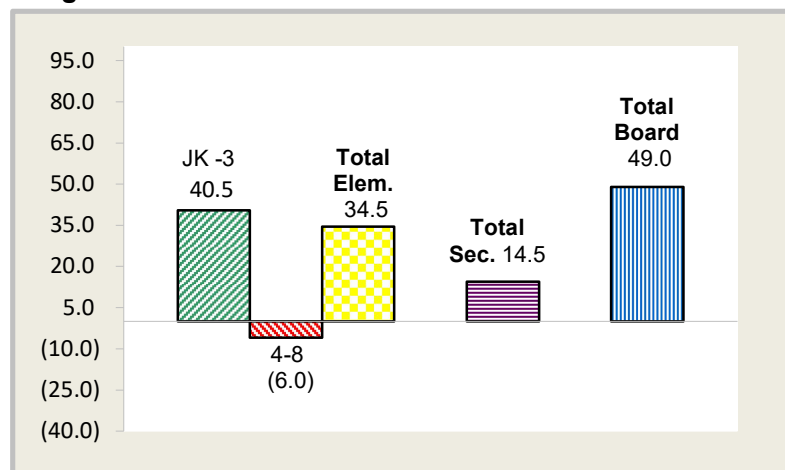

Highlights of Changes in Enrolment:

- Revised Estimates reflects enrolment at October 31 count date
- Net increase of 49 FTE, which is 1.1%
- Majority of elementary increase is kindergartens

Changes in Staffing: Actual vs. Revised Estimates

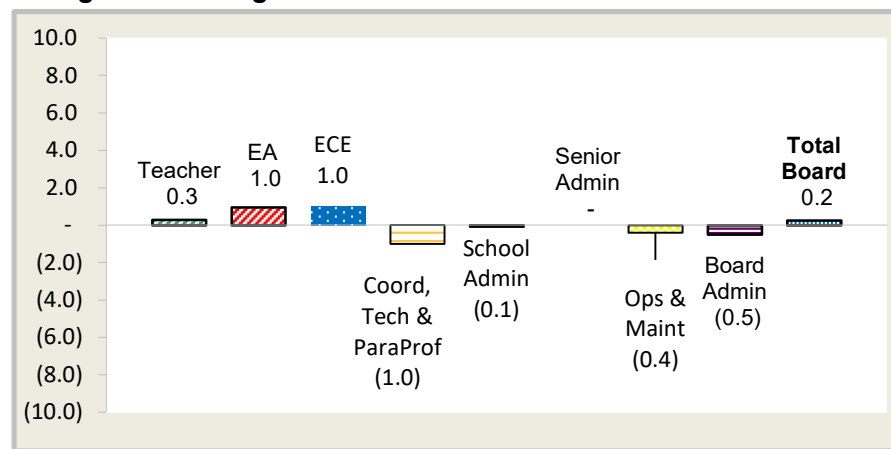

Highlights of Changes in Staffing:

- Teachers & Early Childhood Educators: additional kindergarten class added
- Additional Education Assistant added due to needs
- Custodial reduced FTE due to square footage calculation
- Vacant paraprofessional position



REPORT TO THE HURON-PERTH CATHOLIC DISTRICT SCHOOL BOARD

Prepared by: Sarah Devereaux, Superintendent of Business and Treasurer
Presented to: The Huron-Perth Catholic District School Board
Date: April 27, 2026
Submitted by: Karen Tigani, Director of Education and Secretary

2026-2027 BUDGET COMMUNITY CONSULTATION

Public Session

BACKGROUND

As set out in the 2026-27 Budget Procedures Manual, the Board encourages public participation in all of its activities through a variety of strategies, e.g. general meetings, openness of meetings, accessibility of the public to trustees and administration, etc. These strategies provide the general public with a variety of opportunities throughout the year to provide feedback and input on Board's activities, including fiscal actions. The budget process offers a specific opportunity for the public to be involved in the budget process.

DEVELOPMENT

The Board used the ThoughtExchange platform to obtain community input for its 2026-27 budget. In alignment with the strategic plan, survey questions were asked to help the Board identify what is working well, where investments can have the greatest impact, and opportunities to enhance support across our district.

The Board received 208 complete survey responses compared to 89 participants in the prior year which represents a significant increase in community engagement. The survey primarily engaged parents/guardians, who made up 87% of respondents, with staff accounting for 11% and 2% as parish and other community members.

Responses have been reviewed and will be utilized in budget deliberations. A report of the ThoughtExchange responses is attached.

RECOMMENDATION

THAT the Huron-Perth Catholic District School Board receives the 2026-2027 Budget Community Consultation Report.

Overview

The survey engaged parents/guardians, who made up 87% of respondents, with staff accounting for 11%. There is a strong emphasis on the importance of Catholic faith formation. In terms of academic support, targeted interventions for struggling learners in mathematics and literacy are highly valued. Student engagement programs and extracurricular activities are perceived as crucial for student success, attendance, and well-being.

Faith Formation

How Important is continued investment in Catholic faith formation opportunities?



Which opportunities could strengthen Catholic faith formation across our schools?

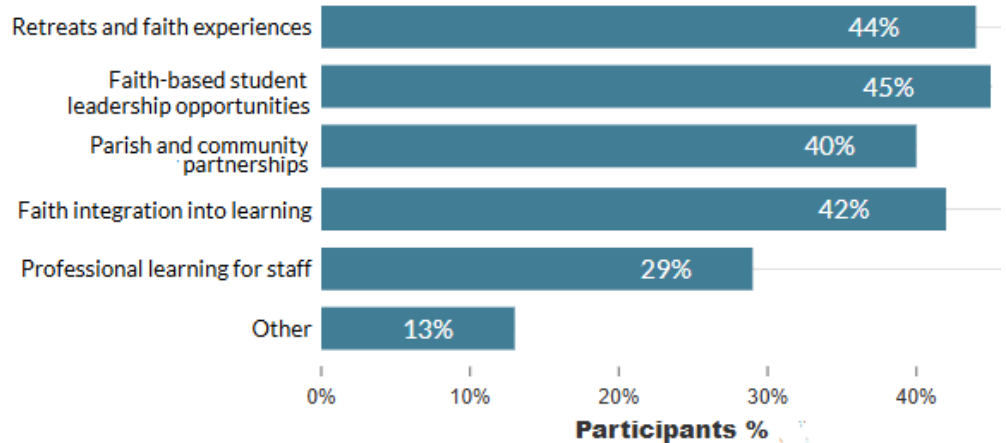

What aspects of Catholic faith formation are working well and should continue to be supported?

- 1 Mass and Sacraments
- 2 Religion Class
- 3 Prayer & Liturgies
- 4 Family & Community Engagement
- 5 Moral & Values Education

Math & Literacy

What supports are most helpful in improving student learning in mathematics & literacy?

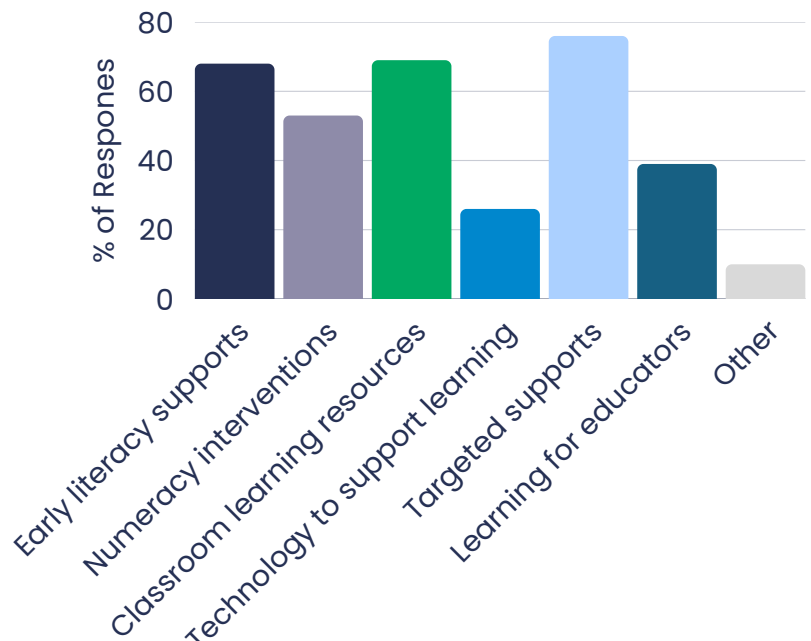



REPORT TO THE HURON-PERTH CATHOLIC DISTRICT SCHOOL BOARD

Prepared by: Sarah Devereaux, Superintendent of Business and Treasurer
Presented to: The Huron-Perth Catholic District School Board
Date: April 27, 2026
Submitted by: Karen Tigani, Director of Education and Secretary

2026-2027 BUDGET REPORT PRELIMINARY ENROLMENT PROJECTIONS

Public Session

BACKGROUND

The Board of Trustees approved the Huron-Perth Catholic District School Board 2026-2027 Budget Procedures Manual at the January 26, 2026 Board meeting. This manual outlined an action plan, and was prepared to guide staff and provide suggested timelines for the development of the 2026-2027 budget.

DEVELOPMENT

Attached reports provide information on 2026-2027 enrolment projections throughout the district. Elementary enrolment is preliminary information, and will continue to be updated based on student registrations until the end of April. Secondary enrolment is finalized based on student course selections.

Elementary enrolment projections are 3,351 average daily enrolment (ADE), which is a decrease of 40 ADE from current year revised estimates projections. The 2025-2026 grade eight cohort moving into grade nine is substantial, therefore a decrease on the elementary panel is expected. Consistent with prior years, final projections will be based on completed registrations including approved interfaith (i.e. non-Catholic) applications, and there will be additional elementary student registrations completed before projections are finalized.

Secondary enrolment projections are 1,326 ADE, which is an increase of 116 ADE from current year revised estimates. Secondary projections are based on the number of completed student choice registrations in the spring, and are confirmed with school administration. Calculations take into account how many of these completed registrations translate to students taking courses and are adjusted based on a five year average. We track and monitor this each year and have found the five year average is accurate. Secondary student enrolment will be reported in the two categories of pupils of the Board and high credit students as ministry funding is different for these two categories.

RECOMMENDATION

THAT the Huron-Perth Catholic District School Board receives the 2026-2027 Preliminary Enrolment Projection Report.

Huron-Perth Catholic District School Board
 2026-27 Enrolment Projections - Preliminary
 DATE: April 10, 2026

Elementary

											A	B	C (A - B)
											2026-27 Preliminary Projections	2025-26 REV EST	Change
School	J	K	1	2	3	4	5	6	7	8	Total		
Holy Name of Mary	18.0	26.0	24.0	21.0	21.0	23.0	26.0	17.0	22.0	11.0	209.0	213.0	(4.0)
Jeanne Sauvé	23.0	30.0	37.0	26.0	21.0	21.0	25.0	21.0	23.0	30.0	257.0	262.0	(5.0)
Our Lady of Mount Carmel	11.0	11.0	16.0	9.0	14.0	16.0	8.0	19.0	16.0	10.0	130.0	135.0	(5.0)
Precious Blood	24.0	28.0	25.0	29.0	28.0	20.0	22.0	24.0	21.0	23.0	244.0	238.0	6.0
Sacred Heart	7.0	17.0	14.0	17.0	20.0	22.0	18.0	26.0	23.0	16.0	180.0	190.5	(10.5)
St. Aloysius	27.0	28.0	27.0	18.0	20.0	22.0	22.0	21.0	31.0	20.0	236.0	251.0	(15.0)
St. Ambrose	13.0	10.0	15.0	15.0	18.0	16.0	12.0	19.0	17.0	23.0	158.0	154.0	4.0
St. Boniface	22.0	24.0	26.0	25.0	15.0	24.0	24.0	24.0	22.0	22.0	228.0	234.0	(6.0)
St. Columban	-	-	-	-	26.0	25.0	32.0	26.0	34.0	28.0	171.0	181.0	(10.0)
St James	19.0	24.0	21.0	26.0	24.0	21.0	19.0	24.0	21.0	22.0	221.0	215.0	6.0
St Joseph's - Stratford	18.0	15.0	20.0	18.0	10.0	13.0	10.0	17.0	9.0	12.0	142.0	136.0	6.0
St Joseph's - Clinton	15.0	24.0	23.0	15.0	30.0	25.0	16.0	28.0	26.0	24.0	226.0	239.0	(13.0)
St. Mary's - Goderich	31.0	26.0	23.0	32.0	33.0	39.0	30.0	35.0	38.0	29.0	316.0	311.0	5.0
St. Mary's - Listowel	46.0	40.0	45.0	38.0	33.0	35.0	33.0	48.0	33.0	44.0	395.0	394.0	1.0
St. Patrick's - Kinkora	9.0	18.0	13.0	11.0	15.0	15.0	9.0	16.0	10.0	10.0	126.0	131.0	(5.0)
St. Patricks - Dublin	32.0	22.0	34.0	24.0	-	-	-	-	-	-	112.0	107.0	5.0
TOTAL Elementary ADE	315.0	343.0	363.0	324.0	328.0	337.0	306.0	365.0	346.0	324.0	3,351.0	3,391.5	(40.5)

25/26 Revised Estimate	325.5	357.0	325.0	325.0	337.0	306.0	362.0	341.0	325.0	388.0	3,391.5		
Difference	(10.5)	(14.0)	38.0	(1.0)	(9.0)	31.0	(56.0)	24.0	21.0	(64.0)	(40.5)		

Secondary

			A	B	C (A-B)
School	October 2026	March 2027	2026-27 Preliminary Projections	2025-26 REV EST	Change
St. Anne	584.3	579.7	582.0	528.4	53.6
St. Michael	759.0	728.4	743.7	681.5	62.2
Total Secondary FTE	1,343.3	1,308.1	1,325.7	1,209.9	115.8

Regular Enrolment	1,310.7	1,196.5	114.2
High Credit Enrolment	15.0	13.4	1.6
	1,325.7	1,209.9	115.8